

CHANGE

HEADQUARTERS
DEPARTMENT OF THE ARMY
Washington, DC 28 April 1992

No, 1

LUBRICATION ORDER

RECOVERY VEHICLE, FULL-TRACKED:
LIGHT, ARMORED, M578
(2350-00-439-6242)

LO 9-2350-238-12, 14 May 1990, is changed as follows:

1. Remove old pages and insert new pages as indicated below.
2. New or changed material is indicated by a vertical bar in the margin of the page.
3. Revised illustrations are indicated by a miniature pointing hand.

Remove Pages

Card 1 of 40 through Card 6 of 40
Card 29 of 40 and Card 30 of 40

Insert Pages

Card 1 of 40 through Card 6 of 40
Card 29 of 40 and Card 30 of 40

4. File this change sheet in the front of the publication for reference purposes.

By Order of the Secretary of the Army:

GORDON R. SULLIVAN
General, United States Army
chief of Staff

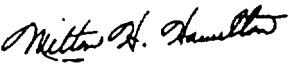
Official: 
MILTON H. HAMILTON
Administrative Assistant to the
Secretary of the Army
01217

DISTRIBUTION:

To be distributed in accordance with DA Form 12-37-E, (Block 1441),
Operator and Unit Maintenance requirements for LO 9-2350-238-12.

LUBRICATION ORDER

LO 9-2350-238-12

14 May 1990

(Supersedes LO 9-2350-238-12; 15 March 1985)

RECOVERY VEHICLE, FULL-TRACKED: LIGHT, ARMORED, M578 (2350-00-439-6242)

Reference: TM 9-2350-238-10, TM 9-2350-238-20

DISTRIBUTION STATEMENT A. Approved for public release; distribution is unlimited.

REPORTING OF ERRORS

You can help improve this publication by calling attention to errors and by recommending improvements and by stating your reasons for the recommendations. Your letter or DA Form 2028, Recommended Changes to Publications and Forms, should be mailed directly to: Commander, US Army Armament, Munitions and Chemical Command, ATTN: AMSMC-MAS, Rock Island, IL 61299-6000. A reply will be furnished directly to you.

This lubrication order is divided into seven sections based on lubrication intervals (daily, weekly, quarterly (3 months), semiannually (6 months), annually (1 year), biennially (2 years), and on-condition).

An overall view showing lubrication points precedes each set of detailed notes.

A broken leader line (- - -) means there are lubrication points on both sides of the vehicle.

Intervals are based on normal operation.

- Lubricate more during constant operation.
- Perform a quarterly lubrication as soon as possible after water fording operation.
- On-condition intervals for oil changes shall be determined by the Army Oil Analysis Program (AOAP) laboratory and shall be applied unless otherwise notified.
- For operation of vehicle in protracted cold temperatures below 0°F (-18 °C), remove lubricants prescribed in the key for temperatures above 0°F (-18 °C), clean parts with dry cleaning solvent, and relubricate with lubricants specified in the key for temperatures +40°F to -70°F (+4°C to -57°C).

MAN-HOUR TIMES

The man-hour time specified is the time you need to do all the services prescribed for a particular interval.

LEVEL OF MAINTENANCE: • C – Operator/Crew
 • 0 – Unit Maintenance

LUBRICATION POINTS

Type of lubricants used at each point are identified by arrows:



- OBSERVE THE FOLLOWING:
- NEVER use the wrong type grease.
 - NEVER use too much lubrication.
 - ALWAYS clean grease fittings before lubrication.
 - ALWAYS use the lubrication order.

KEY

LUBRICANTS	CAPACITIES	EXPECTED TEMPERATURES		INTERVALS	
		Above 0°F (Above -18 °C)	Below + 40 °F Below + 4 °C		
OE/HDO (MIL-L-2104D)	LUBRICATING OIL, Internal Combustion Engine, Tactical Service			D - Daily W - Weekly Q - Quarterly 750 mi (1207 km) or 75 hr of operation, which- ever occurs first S - Semiannually, 1500 mi, (2414 km), or 150 hr of operation, which- ever occurs first A - Annually B - Biennially OC - On-Condition	
OEA (MIL-L-46167)	LUBRICATING OIL, Internal Combustion Engine, Arctic				
	Engine Crenkcase, Add Three Additional Quarts [2.8 l) for filters.	Refill 28 qt (26.5 l) Dry 38 qt (35.9 l)			
	Auxiliary Drive	Refill 4 qt (3.8 l) Dry 4½ qt (4.2 l)	OE/HDO-I 5/40		
	Tow Winch	5 qt (4.7 l)			
	Boom Winch	3 qt (2.8 l)			
	Auxiliary Drive Clutch Housing	Refill ¾ pt (0.35 l) Dry 7/8 pt (0.40 l)	OE/HDO-I 5/40		
	Transmission	Refill 12 gal (45.4 l) Dry 19 gal (72 l)	OEA OE/HDO - 15/40		
	Traversing Gearcase Upper Section	OEA	OEA		
	Traversing Gearcase Lower Section				
	Hydraulic Reservoir	Refill 140 gal (530 l) Dry 165 gal (624.5 l)	OE/HDO-10		
	Final Drive (Left)	13 qt (12.35 l)	OE/HDO-15/40		
	Final Drive (Right)	7 qt (6.65 l)	OEA		
	Road Wheel Hub Bearing Trailing Idler Hub Bearing		GAA		
GAA (MIL-G-10924)	GREASE, Automotive and Artillery		ALL TEMPERATURES		
CLP (MIL-L-63460)	LUBRICANT, CLEANER and PRESERVATIVE Machine Gun Oil Can Points		CLP		
SD2 (P-D-680)	SOLVENT, Dry Cleaning		ALL TEMPERATURES		
CW-11 (VV-L-751) GO-75 (MIL-L-2105)	LUBRICATING OIL, Chain, Wire Rope, Exposed Gear, and Cables	EXPECTED TEMPERATURES			
		Above 80°F (Above 27 °C)	80°F to 30°F (27°C -1°C)	30°F to -30°F (-1°C to -34°C)	-30°F to -65°F (-34°C to -54°C)
		CW-IIC	CW-IIB	CW-IIA	GO-75

For Arctic operation refer to FM 9-207

TOTAL MAN-HOURS		TOTAL MAN-HOURS	
Interval	Man-Hours	Interval	Man-Hours
D	5	A	110
w	8	B	150
Q	20	OC	25
s	30		

DAILY NOTES

This page shows what to check or lubricate each day the vehicle is operated or driven.

LUBRICANT-INTERVAL

INTERVAL-LUBRICANT

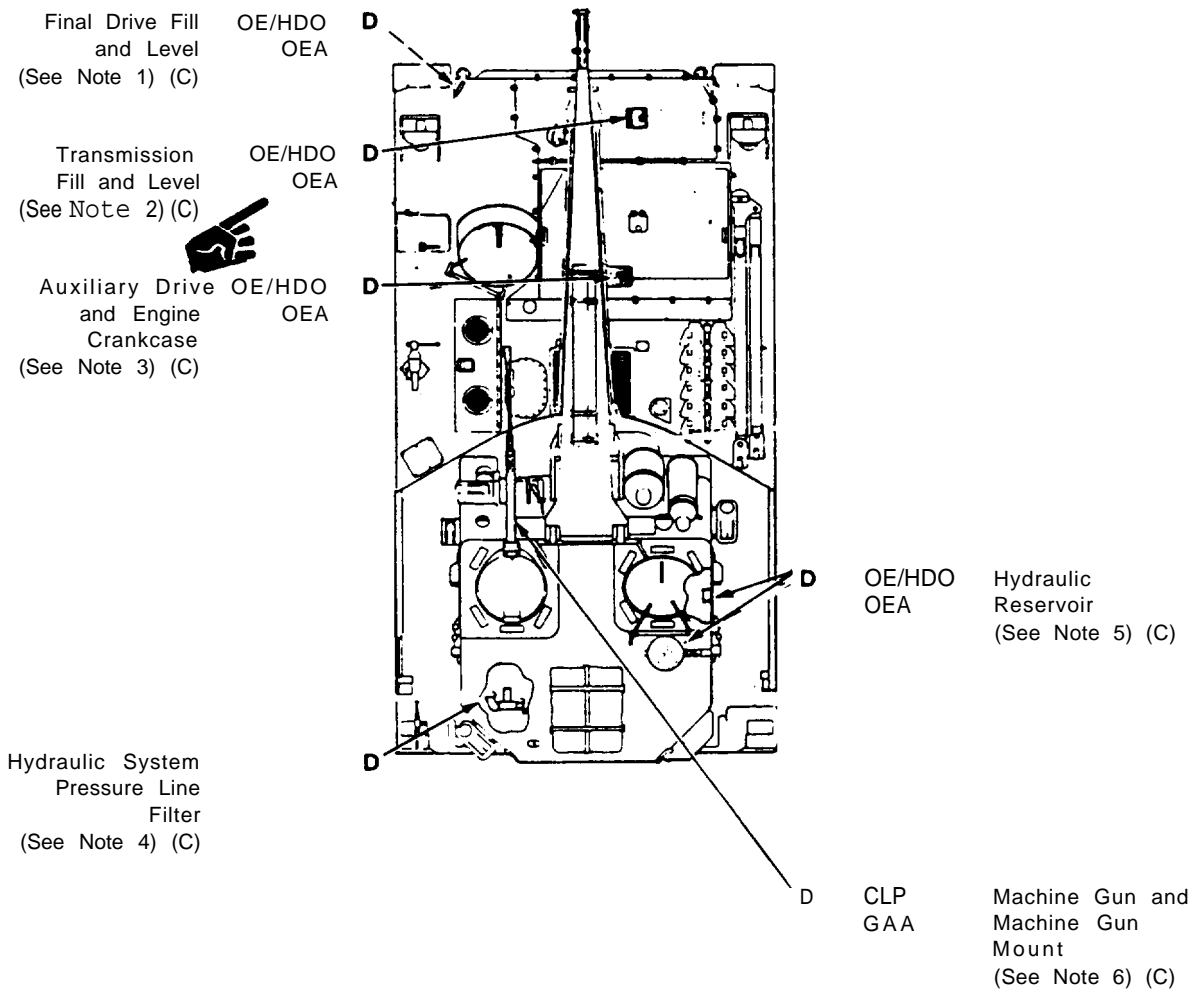

DAILY NOTES (CONTINUED)

Note 1

FINAL DRIVE FILL AND LEVEL

Check oil level from outside vehicle. Fill plug access is under transmission deck.

- A Remove level check plug (1).
- B Check that oil is level with bottom of opening. If not, remove transmission deck and fill plug (2) in final drive saddle.
- C Add oil (OE/HDO or OEA), slowly, until oil flows from check plug (1) opening.

WARNING

Dry cleaning solvent (SD2) is toxic and flammable. Wear protective goggles and gloves and use only in well-ventilated area.

D Clean level check plug (1) and fill plug (2) with solvent SD2 and install.

E Repeat steps A thru D for opposite side.

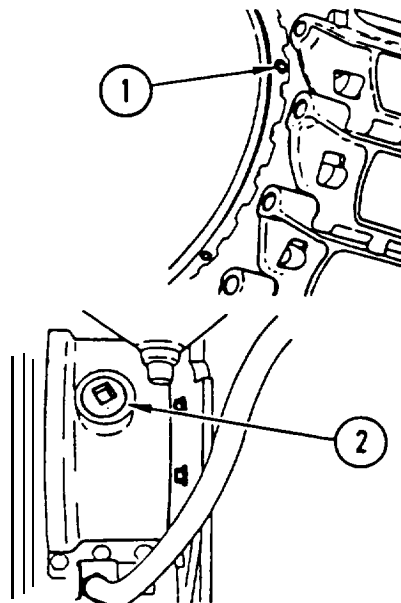

Note 2

TRANSMISSION FILL AND LEVEL

Access is through door in transmission deck.

CAUTION

- Do NOT check oil with engine running.
- Do NOT overfill.

Note

Always think about oil temperature when adding oil. The oil level will vary within OPERATING RANGE due to oil temperature.

- A Check that oil level is within OPERATING RANGE on gage. Do not add or drain oil if in this range. Add oil only when below ADD mark.
- B Add or drain oil (OEA or OE/HDO) as required. See Note 44 for drain procedure.
- C Take oil sample every 25 hours of operation or every 60 days, whichever occurs first. Refer to DA PAM 738-750 for sampling requirements.

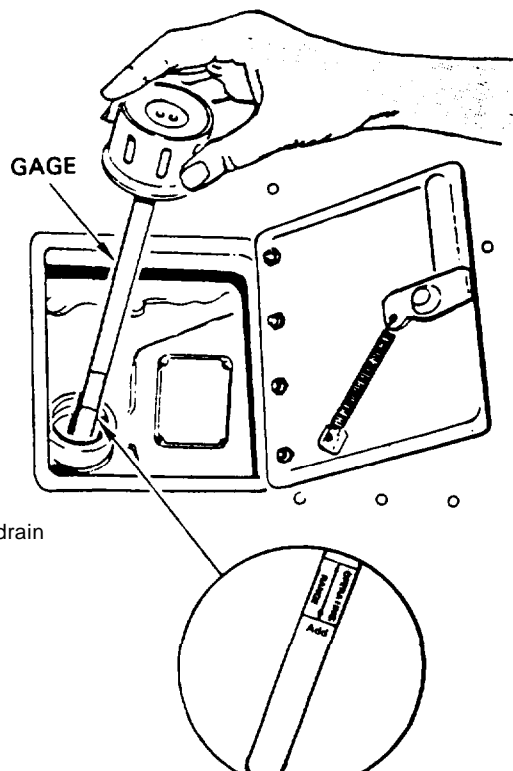

DAILY NOTES (CONTINUED)

Note 3

AUXILIARY DRIVE AND ENGINE CRANKCASE

Access is through door in engine deck.

A Auxiliary Drive

- 1 Lift cap (1) and check oil level. Oil should be within FULL and ADD marks on gage (2).
- 2 Add or drain OE/HDO or OEA, as required.

B Engine Crankcase

Note

After overnight stand, oil level may indicate up to 3/4 in. (19 mm) over FULL mark. This is normal.

Step 1 deleted

- 2 Level should be between low (L) and full (F) marks on gage (3). If required, add or drain oil (OE/HDO or OEA).
- 3 Take oil samples every 25 hours of operation or every 60 days, whichever occurs first. Refer to DA PAM 738-750 for sampling requirements.

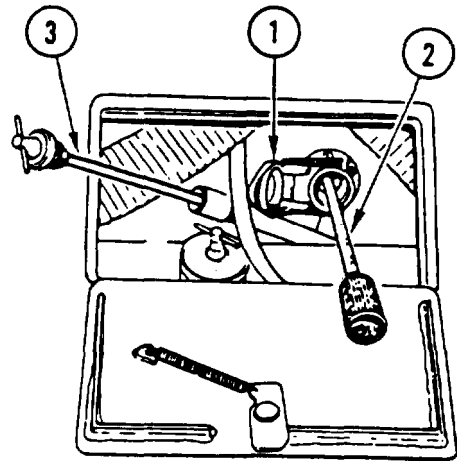

Note 4

HYDRAULIC SYSTEM PRESSURE LINE FILTER

WARNING

Make sure no personnel are in turret well before traversing cab.

CAUTION

Relieve hydraulic pressure before disassembling filter assembly.

Remove stowage box to gain access into turret wall.

- A Check indicator button (1) on filter base (2).
- B When button protrudes 1/4 in. (6 mm) the filter is dirty.

WARNING

Dry cleaning solvent (SD2) is toxic and flammable. Wear protective goggles and gloves and use only in well-ventilated area.

- C Remove filter element (3) and clean inside of case (4) with solvent SD2.
- D Dry case (4) and install new filter element (3).

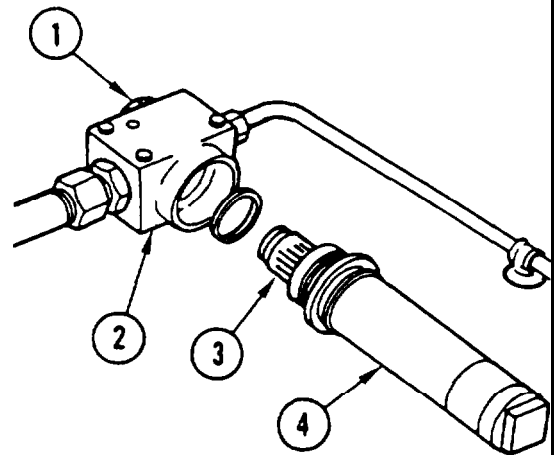

DAILY NOTES (CONTINUED)

Note 5

HYDRAULIC RESERVOIR

Check fluid level from inside cab, fill from outside of cab.

- A Check that fluid level registers to at least halfway on level gage (1).

CAUTION

Before opening filler cap, make sure drain groove (2) is clear of water, dirt, and debris.

- B Open filler cap (3).
- C Add fluid (OE/HDO or OEA) through fill hole (4) until it registers half way on level gage (1).

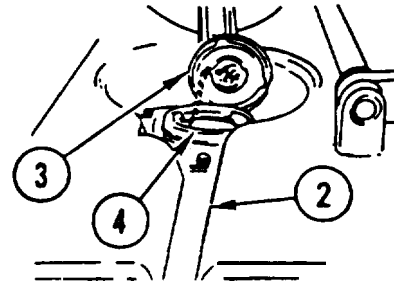
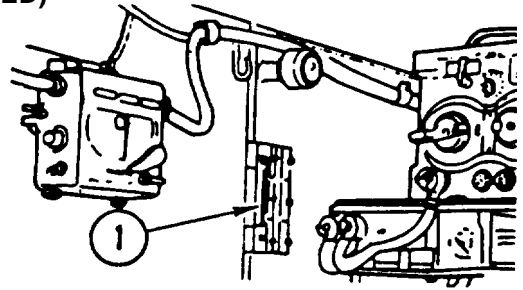

Note 6

MACHINE GUN AND MACHINE GUN MOUNT

Immediately after firing (or as soon as possible) thoroughly clean and lubricate the weapon to maintain reliability and combat effectiveness. Follow the procedures listed below:

- A Disassemble the gun into the groups and assemblies. (See TM 9-1005-213-10).

Note

Do not dip back plate in any solution; clean with swab or rag and CLP.

- B Clean all metal surfaces that are subject to powder fouling with CLP. Wipe dry, and lubricate.
- c Clean bore and chamber with brush or swab, saturated with CLP, until a clean swab can be run through the barrel without detecting any contamination. Wipe dry, and lubricate.
- D Before assembling, inspect and clean the bolt, bolt locking area, and other areas where firing residue has deposited.
- E Inspect each component before assembly, to ensure that lubricant or preservative (CLP) has been applied.
- F Clean all surfaces of pintle and mount with CLP; wipe dry and lubricate pintle shaft with GAA.

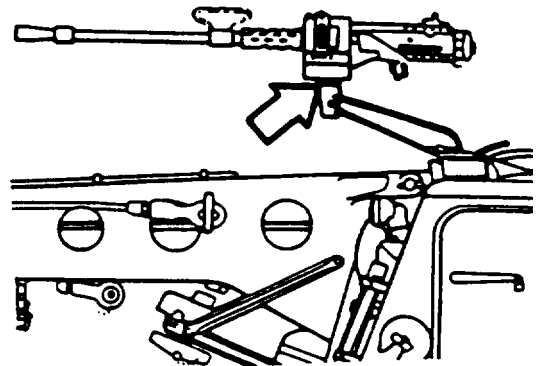

WEEKLY NOTES

LUBRICANT-INTERVAL

INTERVAL-LUBRICANT

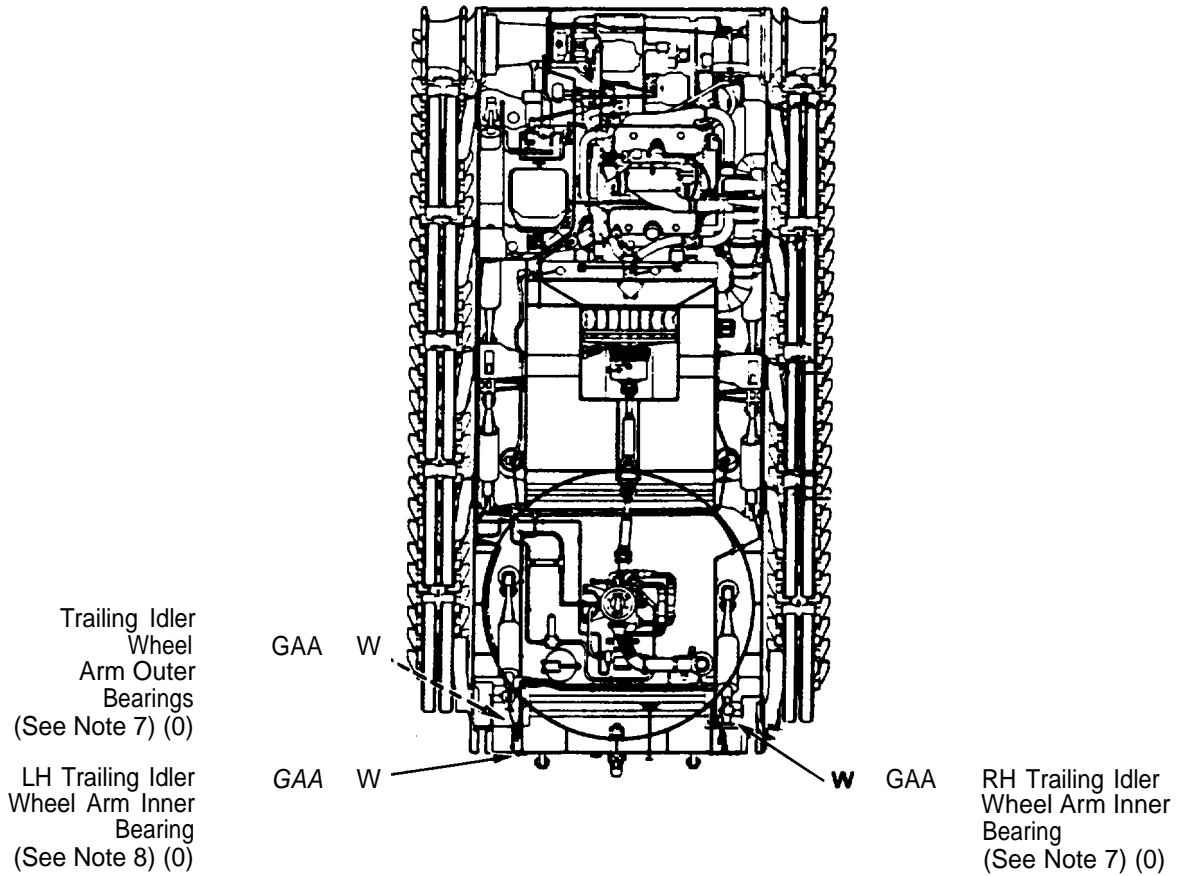

WEEKLY NOTES (CONTINUED)

Note 7

TRAILING IDLER WHEEL ARM OUTER BEARINGS AND RH INNER BEARING

A Lubricate both RH and LH trailing idler wheel arm outer bearings with GAA. Pump grease gun 5 or 6 times to properly lubricate bearings.

B Lubricate RH trailing idler wheel arm inner bearing with GAA. Pump grease gun 5 or 6 times to properly lubricate bearing.

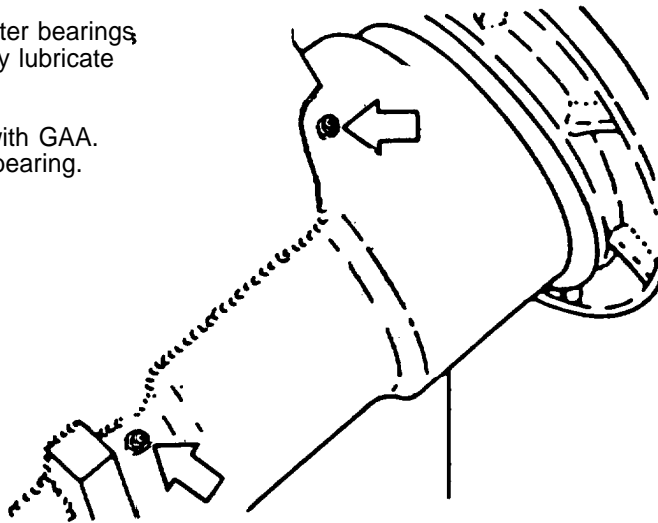

Note 8

LH TRAILING IDLER WHEEL ARM INNER BEARING

Lubricate LH trailing idler wheel arm inner bearing with GAA. Pump grease gun 5 or 6 times to properly lubricate bearing.

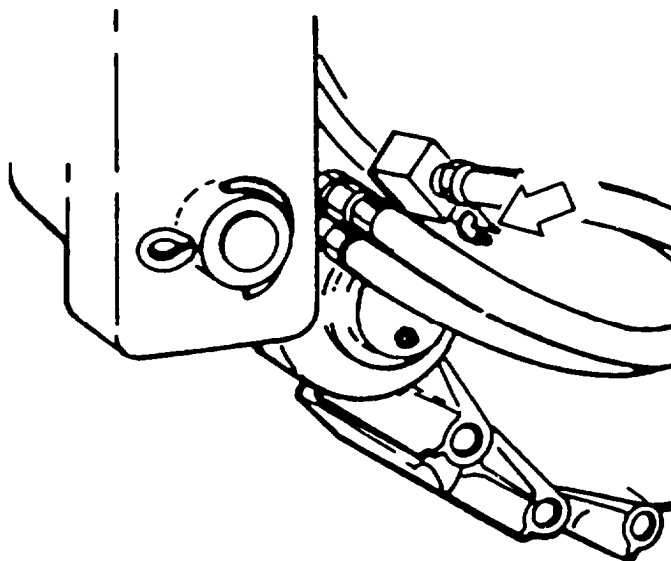

QUARTERLY NOTES

SERVICED FROM
OUTSIDE VEHICLE

LUBRICANT-INTERVAL

INTERVAL-LUBRICANT

Tow Cable
(See Note 9) (C)

Cupola Cover
Hold Open Lock
(See Note 10) (0)

CW-II
GO-75

GAA

Q

Q

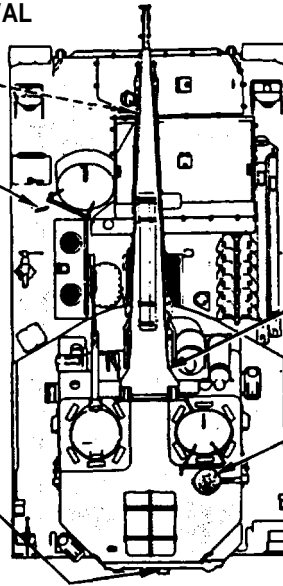

CW-II
GO-75

Boom Winch and
Tow Winch Cables
(See Note 12) (C)

Hydraulic Reservoir
Filter and Strainer
Assembly
(See Note 13) (0)

Towing Pintle
(See Note 11) (0)

GAA

Q

Boom and Boom
Cylinder Hinge
Pins
(See Note 14) (0)

GAA

Q

Level Wind
Housing Bearing
(See Note 15) (0)

GAA

Q

Tow Cable Single
Block Bearing
(See Note 16) (0)

GAA

Q

Boom Sheave
Bearing
(See Note 17) (0)

GAA

Q

Boom Lift Block
Bearing
(See Note 18) (0)

GAA

Q

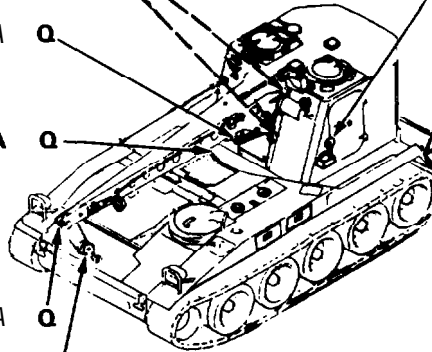

Q

GAA

Snatch Block
Bearing
(See Note 19) (0)

Q

GAA

Moldboard Hinge
Pins
(See Note 20) (0)

Q

GAA

Spade Strut Hinge
Pins
(See Note 21) (0)

Q

GAA

Spade Cylinder
Bracket Hinge Pins
(See Note 22) (0)

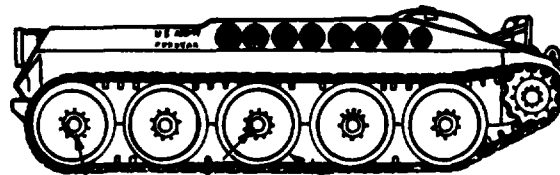

Road Wheel and
Idler Wheel Hub
Bearings
(See Note 23) (0)

OE/HDO Q
OEA
GAA

Q

Q

GAA

Road Wheel Arm
Bearings and Lock-
out Cylinders
(See Note 24) (0)

QUARTERLY NOTES (CONTINUED)

SERVICED THROUGH ENGINE, FAN WELL, AND DRIVER'S COMPARTMENT

LUBRICANT-INTERVAL

INTERVAL-LUBRICANT

Brake Control Shaft
(See Note 25) (0)

GAA Q

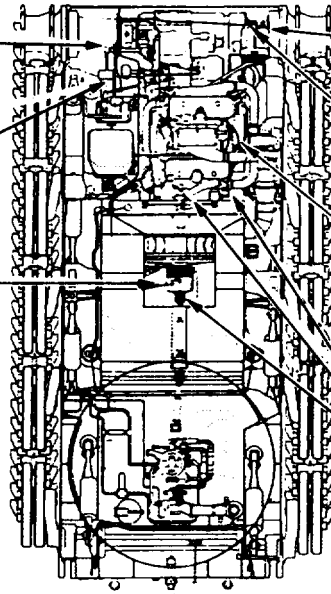

Q

Engine Oil Filters
(See Note 28) (0)

Parking Brake
(See Note 26) (0)

GAA Q

Q

GAA Speedometer Cable Adapter
{See Note 29} (0)

Auxiliary Drive Clutch Housing Breather, Level, and Fill
(See Note 27) (0)

OE/HDO
OEA

Q

Q

GAA Tachometer Cable Adapter
(See Note 30) (0)

Q

GAA Universal Joints
(See Note 31) (0)

SERVICED THROUGH TURRET WELL AND CAB

Universal Joints
(See Note 31) (0)

GAA Q

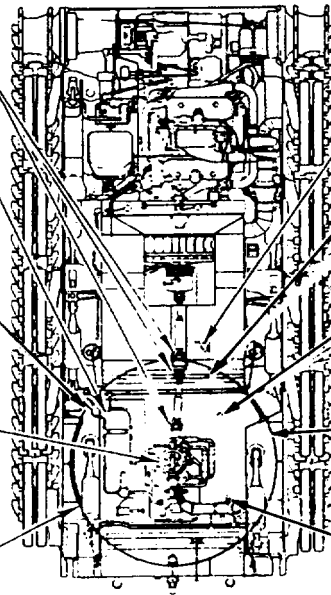

Q

OE/HDO
OEA Boom Winch Fill and Level
(See Note 36) (0)

Traversing Gearcase Fill and Level
(See Note 32) (0)

OEA Q

Q

OE/HDO
OEA Tow Winch Fill and Level
(See Note 37) (0)

Traversing Final Drive Bearings
(See Note 33) (0)

GAA Q

Q

GAA Boom Cylinder Hinge Pins
(See Note 38) (0)

Slip Ring Breather and Bearing
(See Note 34) (0)

GAA Q

Q

GAA Turret Bearing
(See Note 39) (0)

Traversing Ring Gear
(See Note 35) (0)

GAA Q

Q

OE/HDO
OEA Hydraulic Reservoir Breather
(See Note 40) (0)

QUARTERLY NOTES (CONTINUED)

Note 9

TOW CABLE

Quarterly, and after each use, clean cable with OE/HDO, OEA, or CLP; oil with lubricating oil, CW-II or GO-75.

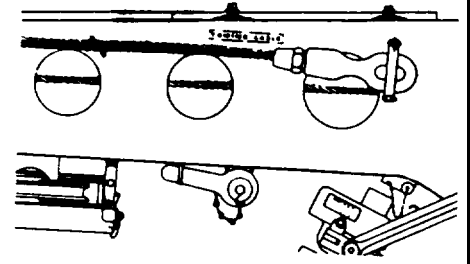

Note 10

CUPOLA COVER HOLD OPEN LOCK

Lubricate fitting with GAA.

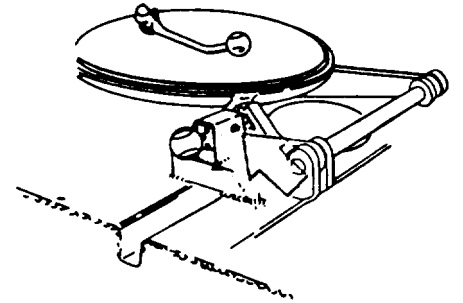

Note 11

TOWING PINTLE

Lubricate three fittings with GAA.

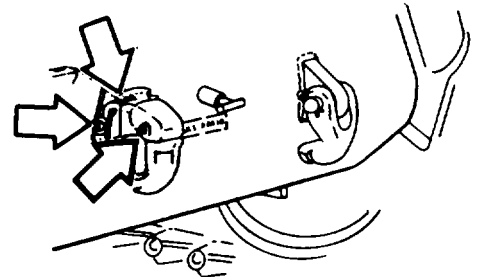

Note 12

BOOM WINCH AND TOW WINCH CABLES

After each use, clean cable with OE/HDO, OEA, or CLP.

Quarterly.

A Unwind entire cable.

B Brush and soak with OE/HDO, OEA, or CLP.

C Wipe off excess oil, and coat cable and drum with lubricating oil, CW-II or GO-75.

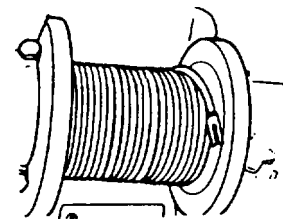

BOOM WINCH CABLE

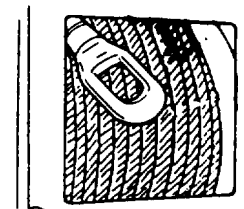

TOW WINCH CABLE

QUARTERLY NOTES (CONTINUED)

Note 13

HYDRAULIC RESERVOIR FILTER AND STRAINER ASSEMBLY

Service quarterly, when reservoir is drained, or upon indication that filter is plugged.

Note

Crane operator's control panel indicator will light when hydraulic fluid is bypassing the filter, indicating the filter is plugged.

- A Open hydraulic reservoir fill cap (1).
- B Remove the following items in the order listed below:
 - 1 Six screws (2) and washers (3).
 - 2 Retaining pin (4).
 - 3 Flange (5).
 - 4 Retainer (6).
 - 5 Gaskets (7).
- C Rotate T-handle (8) in strainer counterclockwise, several turns, to release strainer assembly.
- D Lift filter and strainer assembly from reservoir.

WARNING

Dry cleaning solvent (SD2) is toxic and flammable. Wear protective goggles and gloves and use only in well-ventilated area.

- E Clean filter and strainer assembly with solvent SD2.
- F Dry and inspect filter and strainer assembly.
- G Replace both gaskets (7).
- H Install filter and strainer assembly by reversing removal procedure above.

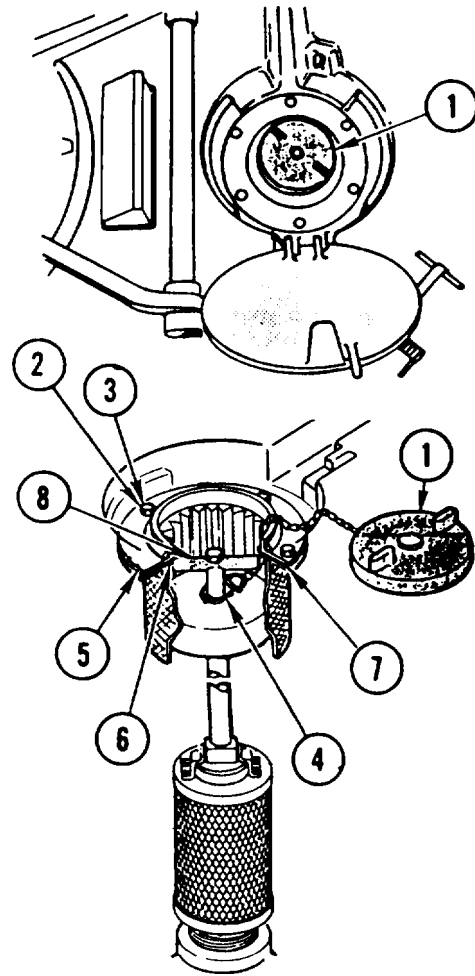

Note 14

BOOM AND BOOM CYLINDER HINGE PINS

Lubricate fittings on both sides of boom with GAA.

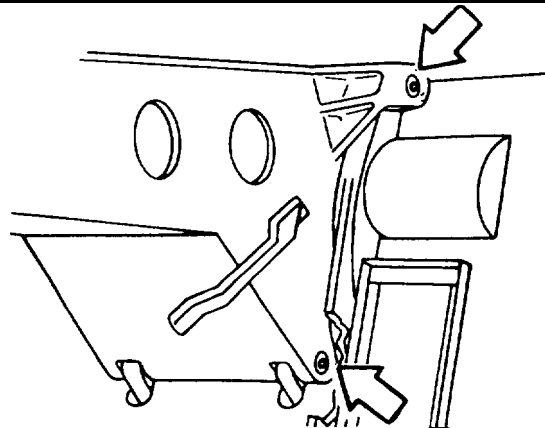

QUARTERLY NOTES (CONTINUED)

Note 15

LEVEL WIND HOUSING BEARING

Lubricate fitting with GAA.

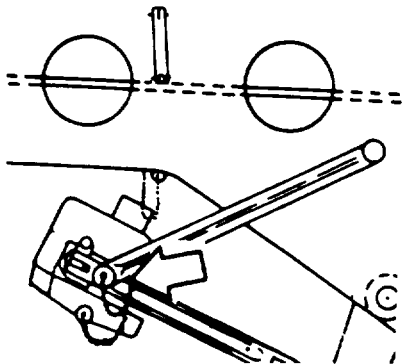

Note 16

TOW CABLE SINGLE BLOCK BEARING

Lubricate fitting with GAA.

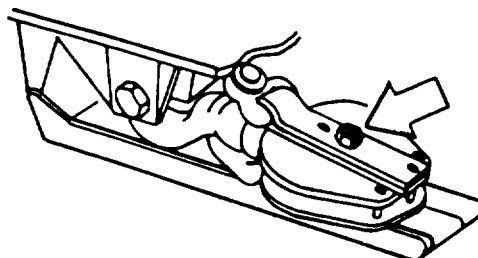

Note 17

BOOM SHEAVE BEARING

Lubricate fitting with GAA.

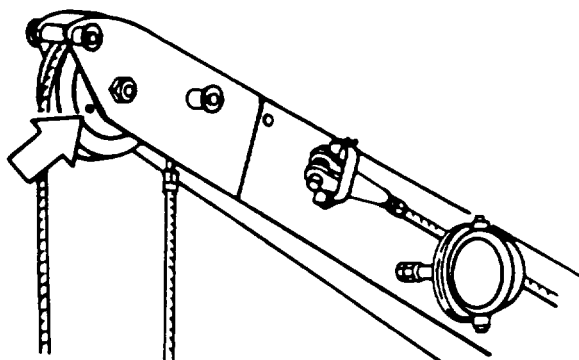

Note 18

BOOM LIFT BLOCK BEARING

Lubricate fitting sparingly with GAA.



Note 19

SNATCH BLOCK BEARING

Lubricate fitting with GAA.

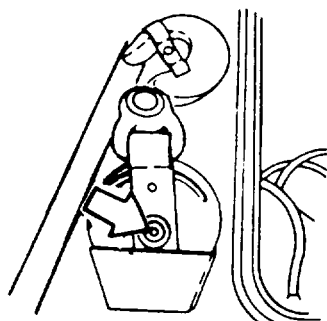

Note 20

MOLDBOARD HINGE PINS

Lubricate both moldboard hinge pin fittings with GAA.

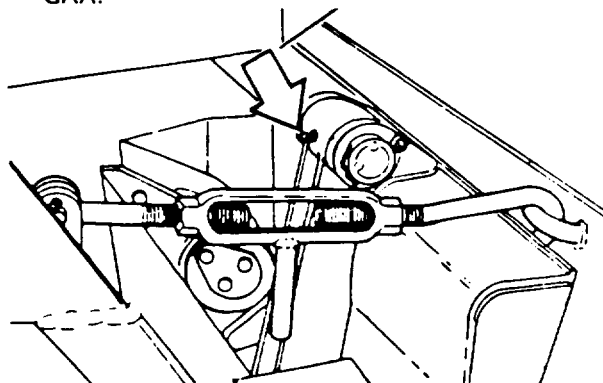

QUARTERLY NOTES (CONTINUED)

Note 21

SPADE STRUT HINGE PINS

Lubricate both spade strut hinge pin fittings with GAA.

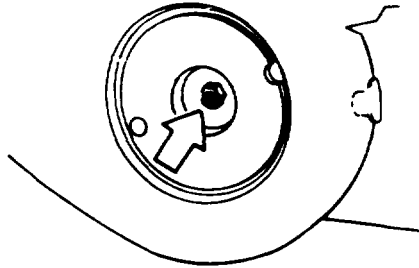

Note 22

SPADE CYLINDER BRACKET HINGE PINS

Lubricate both spade cylinder bracket hinge pin fittings with GAA.

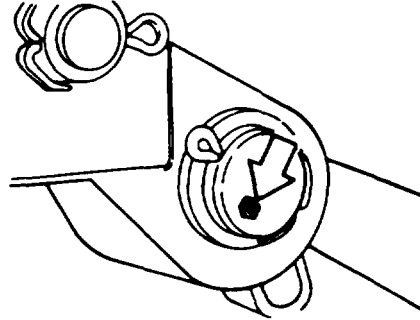

Note 23

ROAD WHEEL AND TRAILING IDLER HUB BEARINGS

Note

Two types of hubs are used on road wheels and trailing idler wheels. One type uses oil (OE/HDO or OEA) for lubrication, the other type uses grease (GAA) for lubrication. Check the road wheel hubs and idler wheel hubs on your vehicle before lubricating.

A Oil Filled Hubs

Check oil level.

- 1 Place vehicle on level ground.
- 2 Remove check plug (1) and observe that oil is level with bottom of hole. Fill if necessary (steps 3 thru 6),
- 3 Rotate wheel until fill plug (2) and drain plug (3) are about vertical.
- 4 Clean area and remove fill plug (2).
- 5 Fill to bottom of level hole with oil (OE/HDO or OEA). Allow time for oil to reach oil cavities.

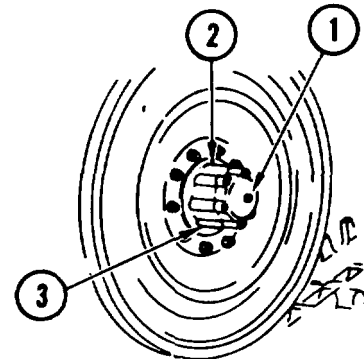

OIL FILLED HUBS

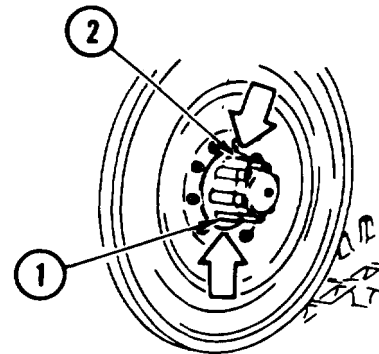

GREASE FILLED HUBS

WARNING

Dry cleaning solvent (SD2) is toxic and flammable. Wear protective goggles and gloves and use only in well-ventilated area.

- 6 Clean fill plug (2) and check plug (1) with solvent SD2 and install.

B Grease Filled Hubs

- 1 Lubricate with GAA.
- 2 Lubricate fitting (1) with GAA until grease comes out of safety relief valve (2).

QUARTERLY NOTES (CONTINUED)

Note 24

ROAD WHEEL ARM BEARINGS AND LOCKOUT CYLINDERS

Lubricate road wheel arm bearings and lockout cylinders weekly, with GAA, when operating in muddy or rough environment. Lubricate quarterly, or every 750 mi (1207 km), during normal operation.

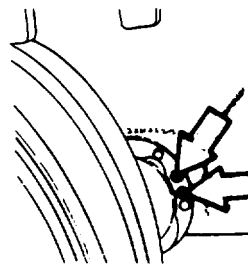

Note 25

BRAKE CONTROL SHAFT

A Service at time of powerplant removal.

B Clean with CLP and coat splines with GAA.

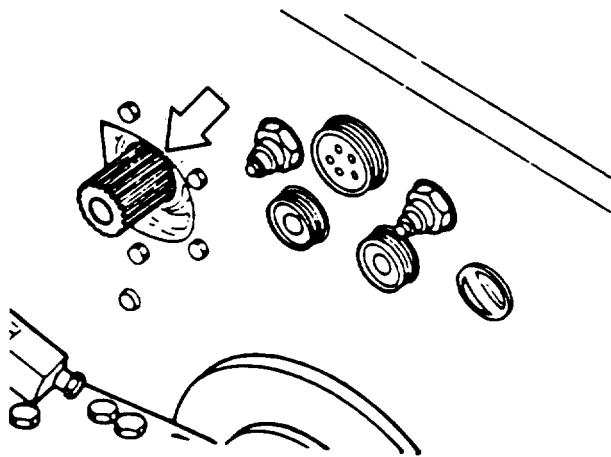

Note 26

PARKING BRAKE

WARNING

Brake pedal is spring loaded. Before working in driver's compartment, block vehicle tracks end release parking brake.

Coat ratchet teeth with GAA and lubricate controls with CLP.

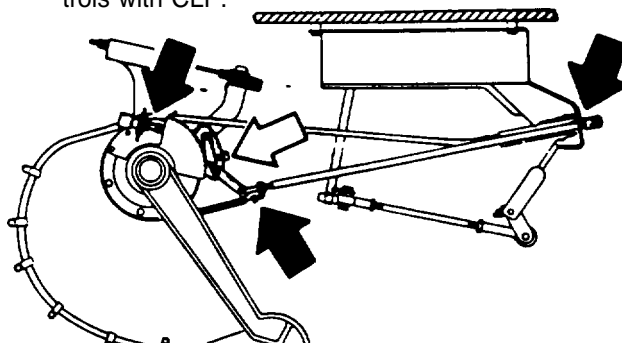

Note 27

AUXILIARY DRIVE CLUTCH HOUSING BREATHER, OIL LEVEL, AND FILL

Clean breather and check oil level.

A Remove fan well cover.

WARNING

Dry cleaning solvent (SD2) is toxic and flammable. Wear protective goggles and gloves and use only in well-ventilated area.

B Remove breather (1), clean with solvent SD2 and install.

C Check that oil level is at FULL mark on gage (2).

D Remove fill plug (3) and fill with oil (OE/HDO or OEA) as necessary.

E Clean fill plug (3) with solvent SD2 and install.

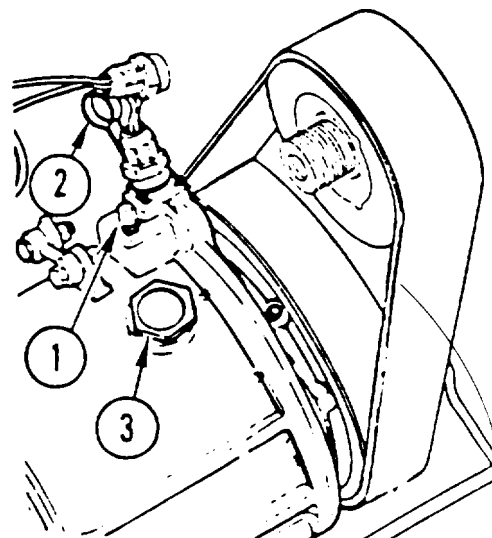

QUARTERLY NOTES (CONTINUED)

Note 28

ENGINE OIL FILTERS

Replace both filter elements quarterly, every 750 mi (1207 km), every 75 hr, or when engine oil is drained.

Note

The following steps are written for one engine oil filter but apply to both.

- A Remove drain plug (1) and drain oil into a suitable container.
- B Loosen shoulder bolt (2) and remove shell (3), filter element (4), and gasket (5).
- C Discard filter element and gasket.

WARNING

Dry cleaning solvent (SD2) is toxic and flammable. Wear protective goggles and gloves and use only in well-ventilated area.

- D Clean plug (1) and shell (3) with solvent SD2, dry thoroughly, and install drain plug (1) in shell (3).
- E Place new gasket (5) in adapter (6) and press into place.
- F Place new filter element in shell (3) and install shell (3) on adapter (6) with drain plug (1) down.
- G Tighten shoulder bolt (2) securely and run engine for a few minutes.
- H Shut off engine and check oil level. Add oil as necessary (see Note 3).

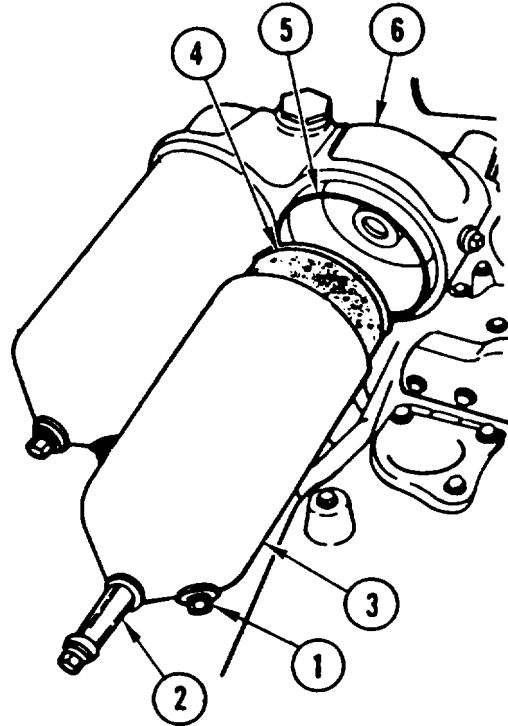

Note 29

SPEEDOMETER CABLE ADAPTER

Lubricate fitting sparingly with GAA.

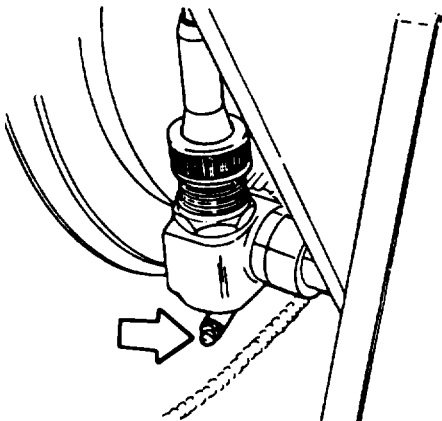

Note 30

TACHOMETER CABLE ADAPTER

Lubricate fitting sparingly with GAA.

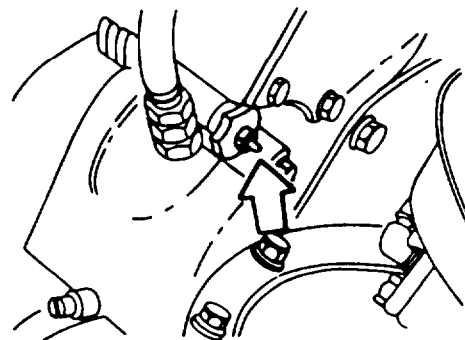

QUARTERLY NOTES (CONTINUED)

Note 31

UNIVERSAL JOINTS

Note

Power plant does not need to be removed to lubricate universal joints.

Lubricate all fittings with GAA. Wipe off extra lubricant.

- A Rotate drive shafts (1) and (2) until lubrication fittings are accessible.
- B Lubricate fittings with GAA and wipe off excess.
- C Rotate turret to rearward position and remove stowage box. Rotate pump drive shaft (3) until lubrication fittings are accessible. Lubricate fitting with GAA and wipe off excess.
- D Remove four screws (4) and disconnect pump drive shaft from carrier bearing (5).
- E Remove lockwire and four screws (6).

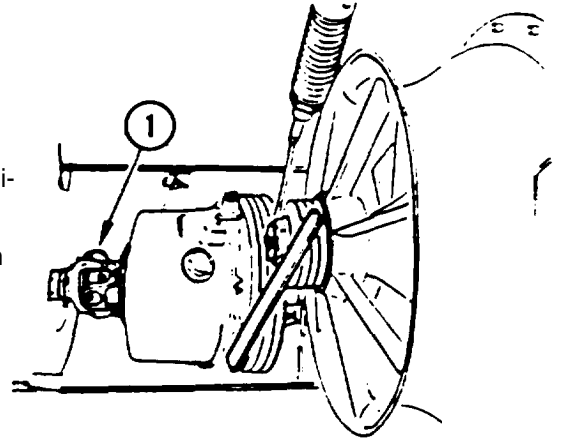

Note

Drive shaft will separate if extended too far. Extend only far enough to gain access to lubrication fittings.

- F Pull carrier bearing (5) just far enough into turret well to gain access to clutch-to-carrier bearing drive shaft lubrication fitting.
- G Lubricate fitting on universal joint with grease (GAA) and wipe off excess.
- H Install carrier bearing and pump drive shaft.

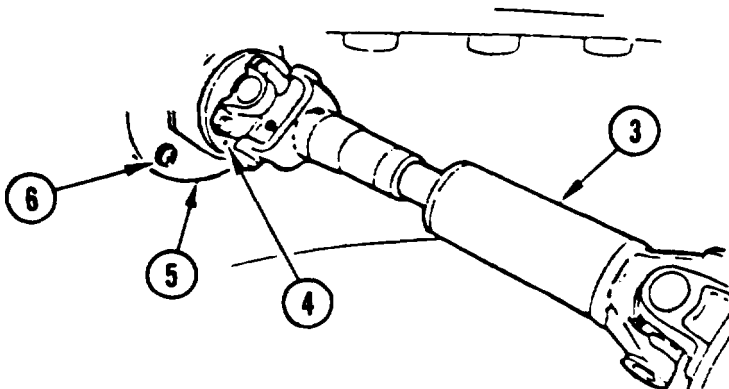
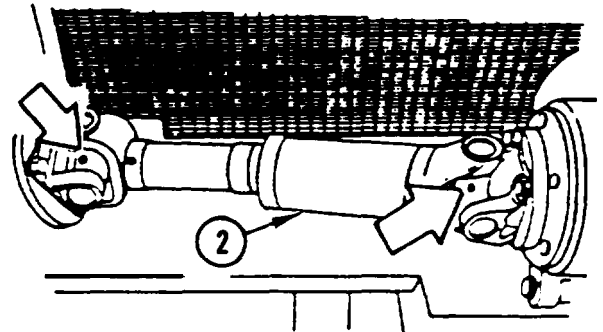

QUARTERLY NOTES (CONTINUED)

Note 32

TRAVERSING GEARCASE FILL AND LEVEL

Check oil level of upper and lower sections.

- A Open access door in left floor cover.
- B To check upper section oil level, remove plug (1) and check that oil level is 1/4 in. (6 mm) below top of plug hole.
- C Fill with oil (OEA) until oil level is 1/4 in. (6 mm) below top of plug hole.

WARNING

Dry cleaning solvent (SD2) is toxic and flammable. Wear protective goggles and gloves and use only in well-ventilated area.

- D Clean plug (1) with solvent SD2 and install.
- E To check lower section, remove plug dipstick (2) and check that oil level indication is at knurled end on dipstick.
- F Fill with oil (OEA) until oil level indicates on knurled end of dipstick.
- G Install plug dipstick (2).

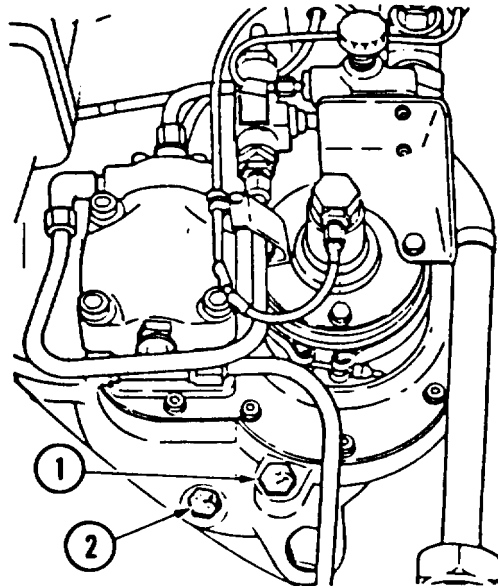

Note 33

TRAVERSING FINAL DRIVE BEARINGS

Lubricate two fittings with GAA.

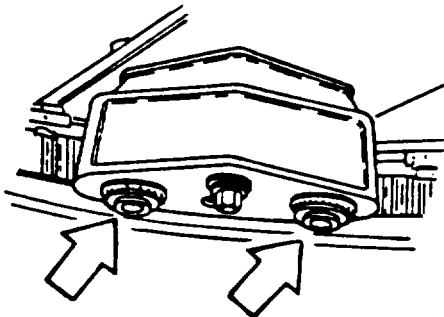

QUARTERLY NOTES (CONTINUED)

Note 34

SLIP RING BREATHER AND BEARING

- A Lubricate fitting on slip ring bearing (1) with GAA,

WARNING

Dry cleaning solvent (SD2) is toxic and flammable.
Wear protective goggles and gloves and use only in
well-ventilated area.

- B Remove breather (2) and clean with solvent SD2.
C Dry, inspect, and install breather (2).

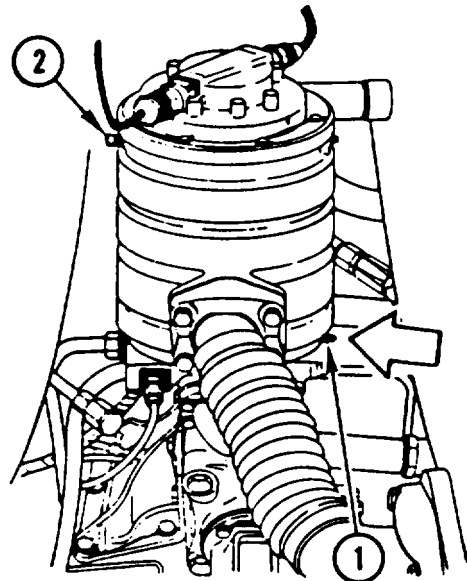

Note 35

TRAVERSING RING GEAR

Clean with CLP and coat with GAA.

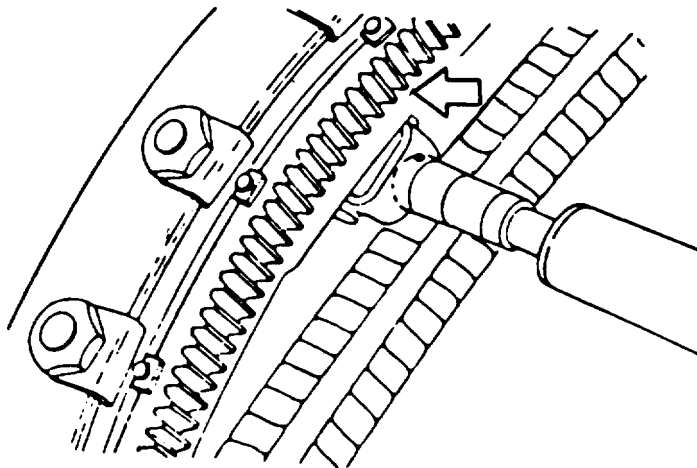

QUARTERLY NOTES (CONTINUED)

Note 36

BOOM WINCH FILL AND LEVEL

Remove boom winch cover to gain access to plugs.

Check oil level.

A Remove fill plug (1) and level plug (2).

B Add oil (OE/HDO or OEA) through fill hole (1) until oil runs out of level plug hole (2).

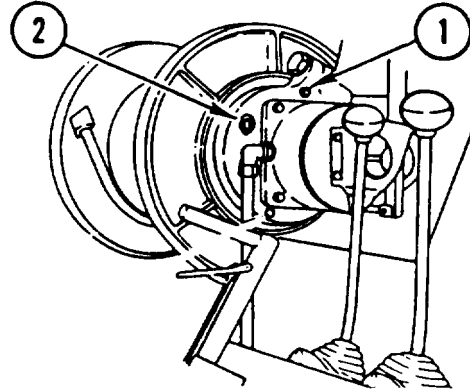

WARNING

Dry cleaning solvent (SD2) is toxic and flammable. Wear protective goggles and gloves and use only in well-ventilated area.

C Clean fill plug (1) and level plug (2) with solvent SD2 and install.

Note 37

TOW WINCH FILL AND LEVEL

Check oil level.

A Rotate drum until check plug (1) is in horizontal (3 or 9 o'clock) position.

B Remove check plug (1) at motor end of winch.

C Remove fill plug (2) at brake end.

D Add oil (OE/HDO or OEA) through fill hole (2) until oil runs out of check plug hole (1).

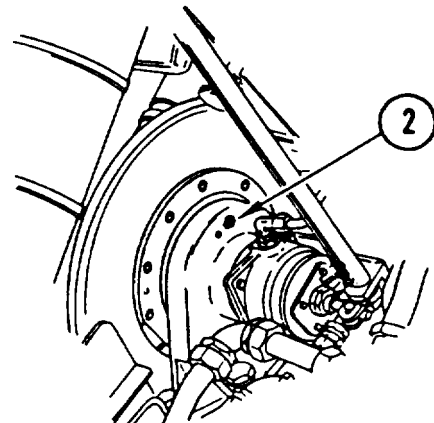
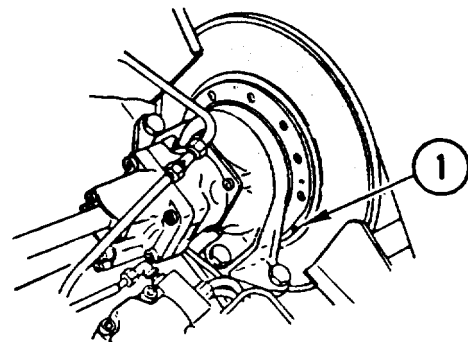

WARNING

Dry cleaning solvent (SD2) is toxic and flammable. Wear protective goggles and gloves and use only in well-ventilated area.

E Clean fill plug (2) and check plug (1) with solvent SD2 and install.

QUARTERLY NOTES (CONTINUED)

Note 38

BOOM CYLINDER HINGE PINS

Lubricate two fittings with GAA.

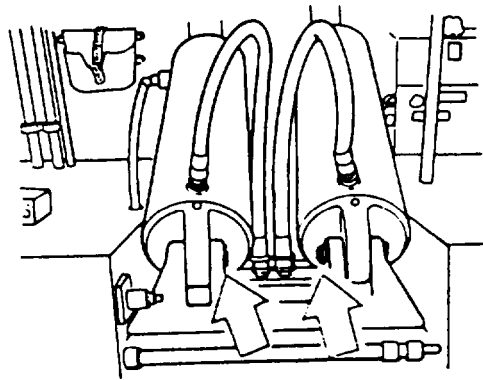

Note 39

TURRET BEARING

WARNING

Make sure no personnel are in turret well before traversing cab.

Lubricate quarterly, after 75 hr of operation, or after each cleaning operation, when turret well is exposed to steam or high-pressure water.

A Apply GAA to both lubrication fittings (1) until clean grease is observed at seals (2).

B Wipe away dirty grease that is forced through seals.

C Repeat until only clean grease is observed at seals.

D Traverse cab four complete revolutions, alternating left and right.

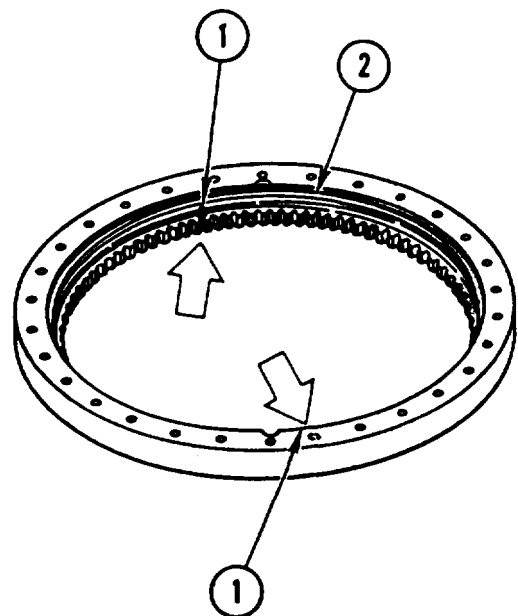

Note 40

HYDRAULIC RESERVOIR BREATHER

WARNING

Dry cleaning solvent (SD2) is toxic and flammable. Wear protective goggles and gloves and use only in well-ventilated area.

A Remove breather (1) and clean with solvent SD2.

B Dry, inspect, dip in oil (OE/HDO-10/OEA), and install.

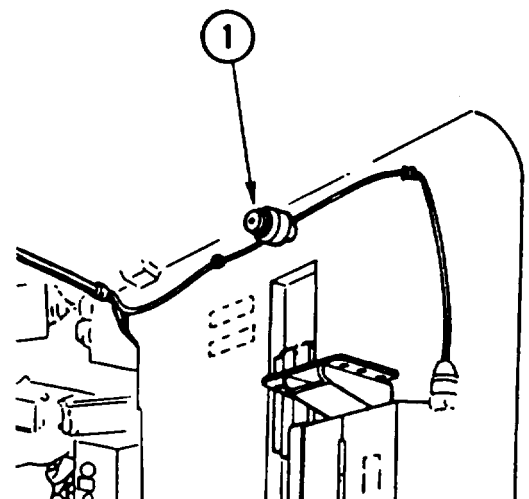

SEMIANNUAL NOTES

LUBRICANT-INTERVAL

INTERVAL-LUBRICANT

Final Drive
Breathers
(See Note 41) (0)

Auxiliary Drive
Drain
and Fill
(See Note 42) (0)

Tow Winch
Breather
(See Note 43) (0)

Tow Hooks
(See Note 46) (0)

Final Drive
Drain and Fill
(See Note 47) (0)

**OE/HDO
OEA**

GAA

**OE/HDO
OEA**

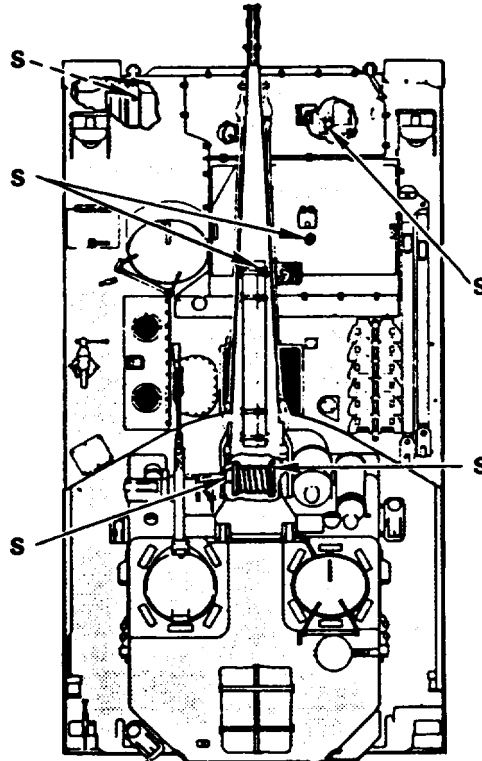

Transmission Oil
Filter
(See Note 44) (0)

OE/HDO Boom Winch and
OEA Tow Winch Drum
CLP and Cable
CW-II (See Note 45) (0)

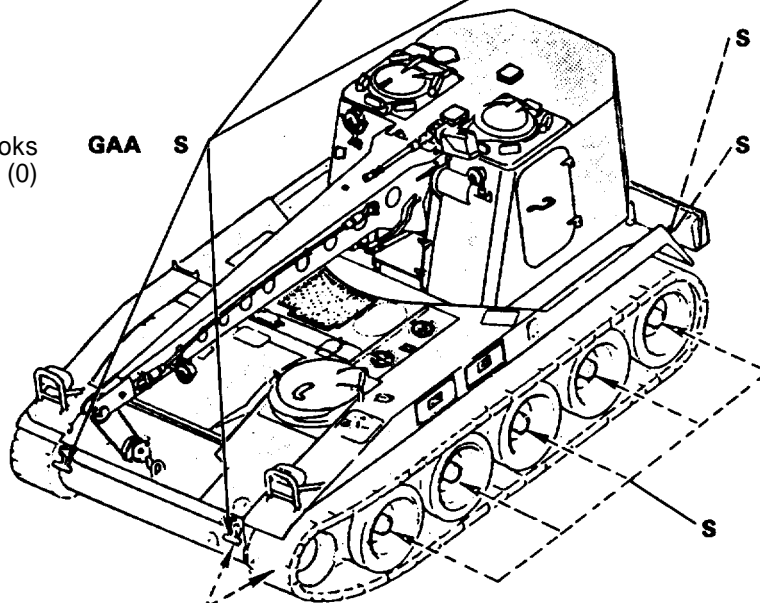

GAA

GAA

**OE/HDO
OEA**

Pins
(See Note 49) (0)

Hub Bearings
Drain and Fill
(See Note 50) (0)

SEMIANNUAL NOTES (CONTINUED)

Note 41

FINAL DRIVE BREATHERS

WARNING

Brake pedal is spring loaded. Before working in driver's Compartment, block vehicle tracks and release parking brake.

Access to LH final drive breather (1) is through driver's compartment. Access to RH final drive breather (2) is through transmission deck.

WARNING

Dry cleaning solvent (SD2) is toxic and flammable. Wear protective goggles and gloves and use only in well-ventilated area.

- A Remove breathers (1) and (2) and clean with solvent SD2.
- B Dip in oil (OE/HDO or OEA) and install.

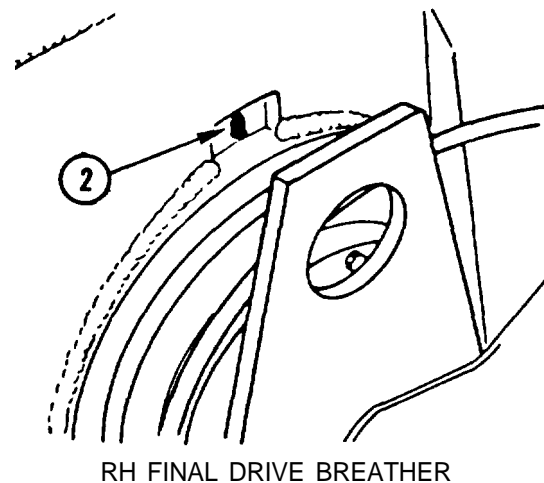
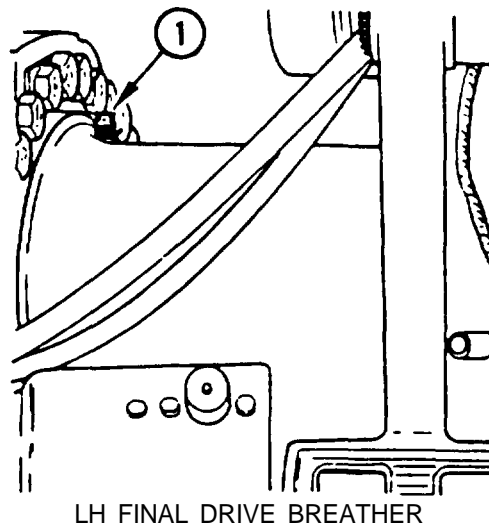

SEMIANNUAL NOTES (CONTINUED)

Note 42

AUXILIARY DRIVE DRAIN AND FILL

WARNING

Oil will be hot after operation.

Note

Drain only after operation.

- A Remove engine crankcase drain cover (1) from bottom of hull.
- B Remove auxiliary drive drain cap (2) and drain oil into a suitable container.

WARNING

Dry cleaning solvent (SD2) is toxic and flammable. Wear protective goggles and gloves and use only in well-ventilated area.

- C After draining, clean auxiliary drive drain cap (2) with solvent SD2 and install drain cap and engine crankcase drain cover (1).
- D Open fill cap (3). Fill with oil (OE/HDO or OEA) until oil level is within FULL and ADD marks on gage (4).
- E Clean and close fill cap (3).

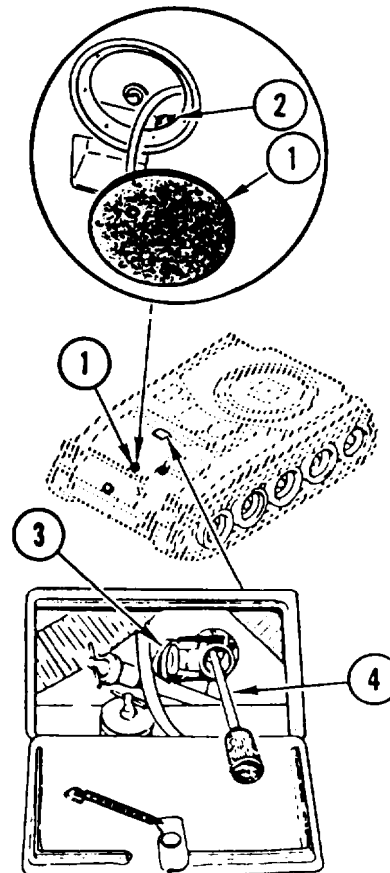

Note 43

TOW WINCH BREATHER

WARNING

Dry cleaning solvent (SD2) is toxic and flammable. Wear protective goggles and gloves and use only in well-ventilated area.

- A Remove breather (1) and clean with solvent SD2.
- B Dry, inspect, dip in oil (OE/HDO), and install.

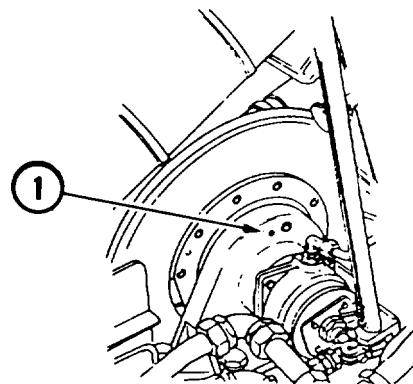

SEMIANNUAL NOTES (CONTINUED)

Note 44

TRANSMISSION OIL FILTER

Replace filter element every 1500 mi (2414 km), every 150 hr, or semiannually, whichever occurs first, and each time the transmission oil is drained.

- A Remove three screws (1) and three washers (2).
- B Install two screws (1) in jack screw holes (3).
- C Tighten screws (1) until filter assembly (4) is loose and remove filter and screws (1).
- D Remove nut (5), element (6), and packing (7). Discard element and packing.

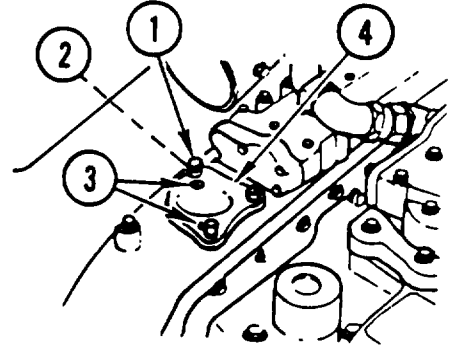

WARNING

Dry cleaning solvent (SD21 is toxic and flammable. Wear protective goggles and gloves and use only in well-ventilated area.

- E Clean parts with solvent SD2 and allow to dry thoroughly.
- F Install new packing (7), new element (6), and nut (5).
- G Install filter assembly (4), using three washers (2) and three screws (1).
- H Run engine and shift transmission several times to check for leaks.

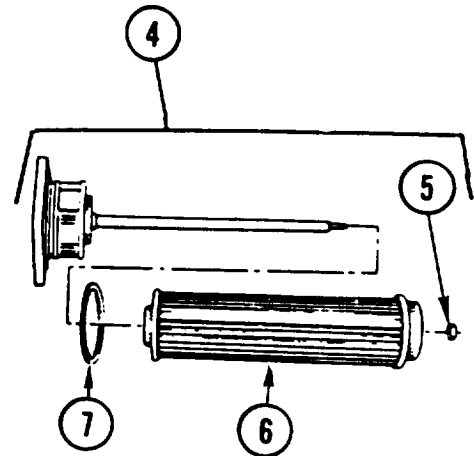

SEMIANNUAL NOTES (CONTINUED)

Note 45

BOOM WINCH AND TOW WINCH DRUM AND CABLE

Perform the following semiannually if winch or cable has not been used.

- A Unwind and clean entire cable.
- B Brush-soak cable and drum with oil (OE/HDO, OEA, or CLP).
- C Wipe off excess oil and coat cable and drum with lubricating oil, CW-II.

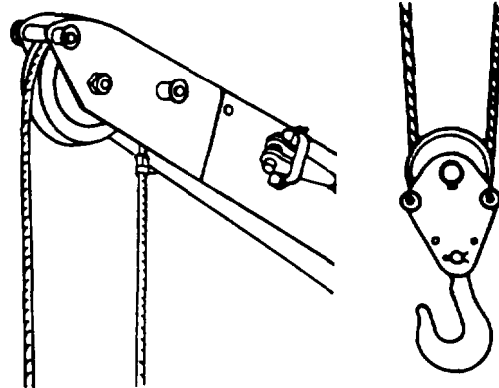
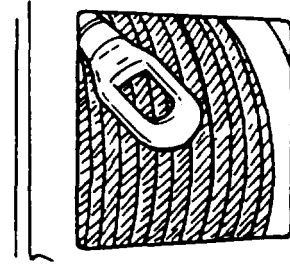

BOOM AND TOW
WINCH CABLES

Note 46

TOW HOOK PINS

- A Remove pins.

WARNING

Dry cleaning solvent (SD2) is toxic and flammable.
Wear protective goggles and gloves and use only in
well-ventilated area.

- B Clean pins with SD2.
- C Lubricate with GAA and install.
- D Wipe off excess grease.

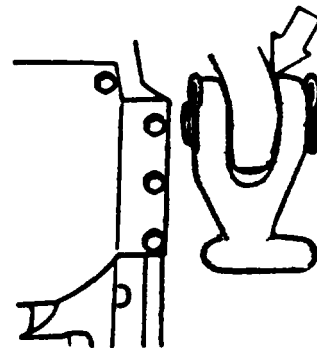

TOW HOOK

SEMIANNUAL NOTES (CONTINUED)

Note 47

FINAL DRIVE DRAIN AND FILL

WARNING

Oil will be hot after operation.

Drain oil from both final drives.

Note

Drain only after operation.

A Remove level plug (1) and drain plug (2) and drain oil into a suitable container.

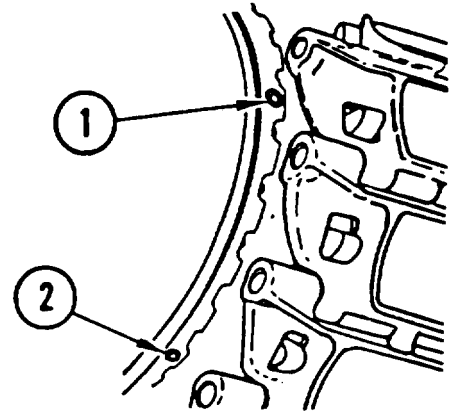

WARNING

Dry cleaning solvent (SD2) is toxic and flammable. Wear protective goggles and gloves and use only in well-ventilated area.

B Clean drain plug (2) with solvent SD2 and install.

C Remove fill plug (3) in final drive saddle.

D Slowly add oil (OE/HDO or OEA) through fill plug hole (3) until oil flows from level plug hole (1).

E Clean plugs (1) and (3) with solvent SD2 and install.

F Repeat steps A thru E for other side.

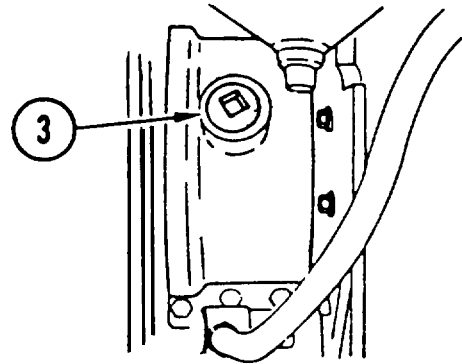

Note 48

SPADE CYLINDER HINGE PINS

A Remove pins.

WARNING

Dry cleaning solvent (SD2) is toxic and flammable. Wear protective goggles and gloves and use only in well-ventilated area.

B Clean pins with SD2.

C Lubricate with GAA and install.

D Wipe off excess grease.

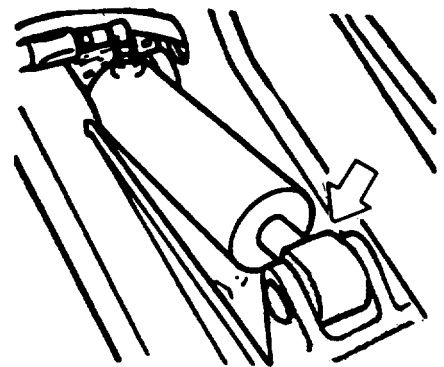

SPADE CYLINDER HINGE PINS

SEMIANNUAL NOTES (CONTINUED)

Note 49

SPADE MOLDBOARD PINS

- A Remove pins.

WARNING

Drycleaning solvent (SD2) is toxic and flammable. Wear protective goggles and gloves and use only in well-ventilated area.

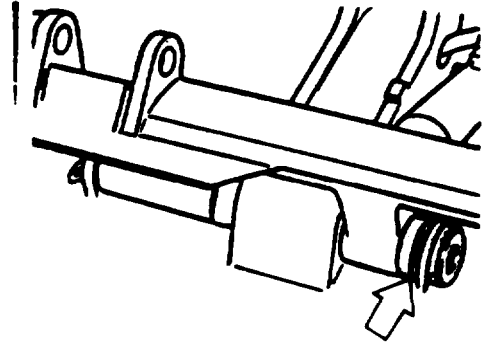

- B Clean pins with SD2.
C Lubricate with GAA and install.
D Wipe off excess grease.

Note 50

ROAD WHEEL AND IDLER WHEEL HUB BEARINGS DRAIN AND FILL

Drain every 1500 mi (2414 km) or semiannually, whichever occurs first.

- A Rotate wheel until fill plug (1) and drain plug (2) are about vertical.
B Remove check plug (3) and drain plug (2) and drain oil into a suitable container.

WARNING

Dry cleaning solvent (SD2) is toxic and flammable. Wear protective goggles and gloves and use only in well-ventilated area.

- C Clean drain plug (2) with solvent SD2 and install.
D Clean area and remove fill plug (1).
E Fill to bottom of level hole with oil (OE/HDO or OEA). Allow time for oil to reach oil cavities.
F Clean check plug (3) and fill plug (1) with solvent SD2 and install.

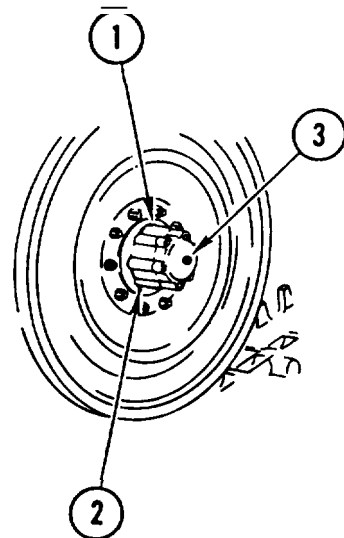

ANNUAL NOTES

LUBRICANT-INTERVAL

INTERVAL-LUBRICANT

Boom Winch
Drain and Fill
(See Note 51) (0)

Traversing
Gearcase
Swivel Joint
(See Note 52) (0)

Traversing Gear-
case Drain and Fill
(See Note 52) (0)

OE/HDO A
OEA

GAA A

OEA A

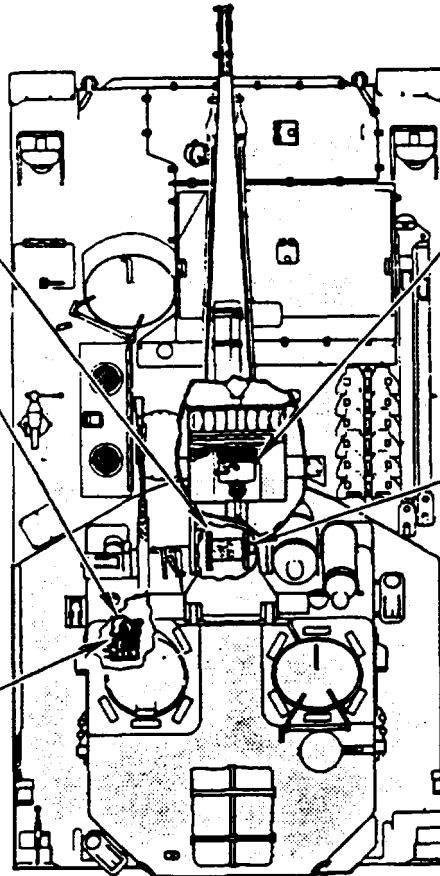

OE/HDO Auxiliary Drive
OEA Clutch Housing
Drain and Fill
(See Note 53) (0)

OE/HDO Tow Winch Drain
OEA and Fill
(See Note 54) (0)

Note 51

BOOM WINCH DRAIN AND FILL

Drain oil from winch.

A Remove fill plug (1), drain plug (2), and level plug (3).

B Drain oil into a suitable container.

WARNING

Dry cleaning solvent (SD2) is toxic and flammable. Wear protective goggles and gloves and use only in well-ventilated area.

C Clean drain plug (2) with solvent SD2 and install.

D Fill with oil (OE/HDO or OEA) at fill plug (1) until oil runs out of level plug (3) hole.

E Clean fill plug (1) and level plug (3) with solvent SD2 and install.

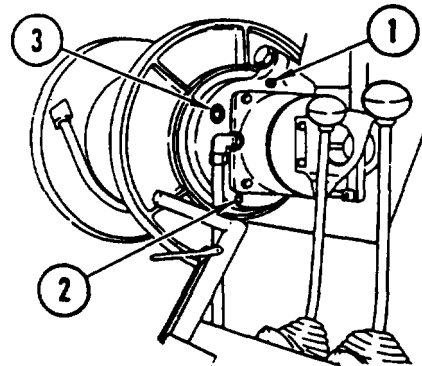

ANNUAL NOTES (CONTINUED)

Note 52

TRAVERSING GEARCASE DRAIN AND FILL

Drain gearcase and lubricate upper section swivel joint.

Note

Drain only after operation.

- A Open access door in left floor cover.
- B Remove upper gearcase fill plug (1).
- C Insert 1/4 in. square drive extension through gearcase fill plug (1) and remove intermediate plug (2),
- D Remove cap (3) from oil drain line and drain oil into a suitable container.

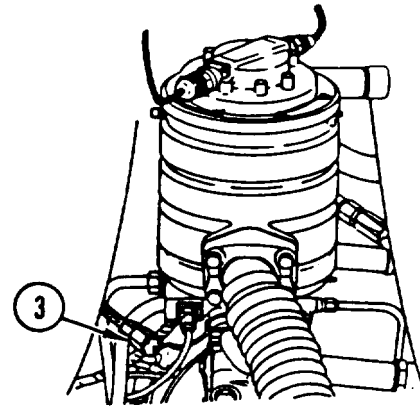

WARNING

Dry cleaning solvent (SD2) is toxic and flammable. Wear protective goggles and gloves and use only in well-ventilated area.

- E Clean intermediate plug (2) and drain line cap (3) with solvent SD2 and install.
- F Remove lower section fill plug (4) and fill with oil (OEA) until it reaches knurled end of gage on lower fill plug.
- G Fill upper section with oil (OEA) to about 1/4 in. (6 mm) below top of fill hole.
- H Install upper gearcase fill plug (1).
- I Lubricate upper section swivel joint (5) with GAA.

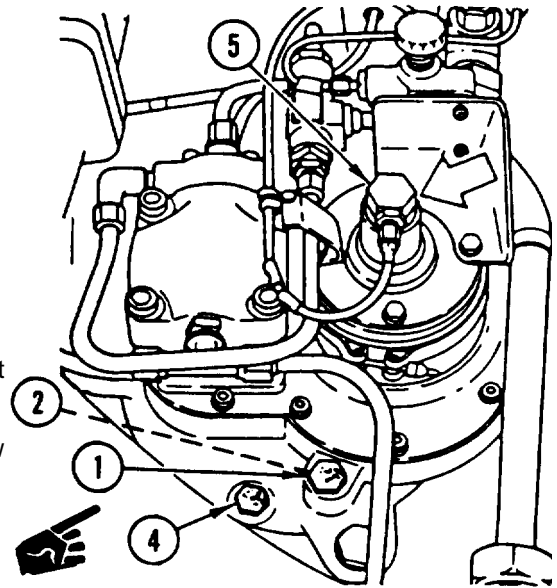

Note 53

AUXILIARY DRIVE CLUTCH HOUSING DRAIN AND FILL

Drain oil from clutch housing.

- A Remove drain plug (1) and drain oil into a suitable container.

WARNING

Dry cleaning solvent (SD2) is toxic and flammable. Wear protective goggles and gloves and use only in well-ventilated area.

- B Clean drain plug (1) with solvent SD2 and install.
- C Remove fill plug (2) and add oil (OE/HDO or OEA) to full mark on gage (3).
- D Clean fill plug (2) with solvent SD2 and install.

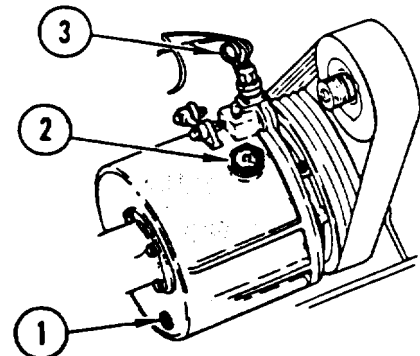

ANNUAL NOTES (CONTINUED)

Note 54

TOW WHINCH DRAIN AND FILL

Drain oil from tow winch.

A Rotate drum until drain and check plugs (1) and (2) are down.

B Remove drain and check plugs (1) and (2) from both ends of drum and drain oil into a suitable container.

WARNING

Dry cleaning solvent (SD2) is toxic and flammable. Wear protective goggles and gloves and use only in well-ventilated area.

C Clean drain and check plug (1) with solvent SD2 and install in brake end.

D Rotate drum until drain and check plug (1) is horizontal (3 or 9 o'clock) position.

E Remove fill plug (3) from support bracket.

F Add oil (OE/HDO or OEA) at fill plug (3) opening until oil comes out drain and check plug (2) opening at motor end.

G Clean drain and check plug (2) and fill plug (3) with solvent SD2 and install.

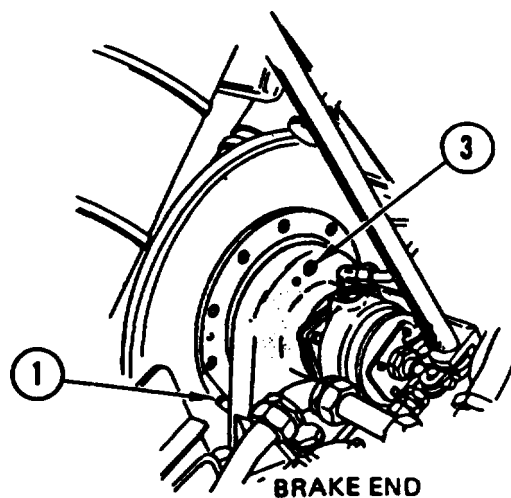
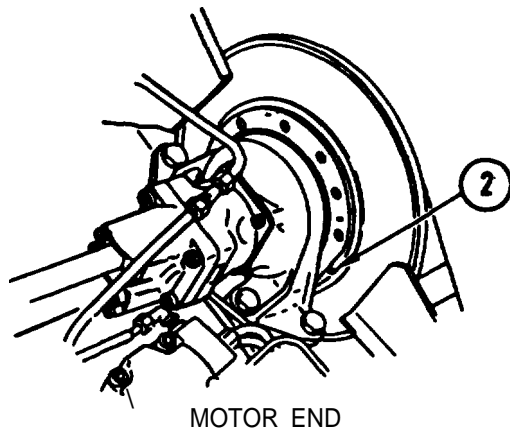

BIENNIAL NOTES

INTERVAL-LUBRICANT

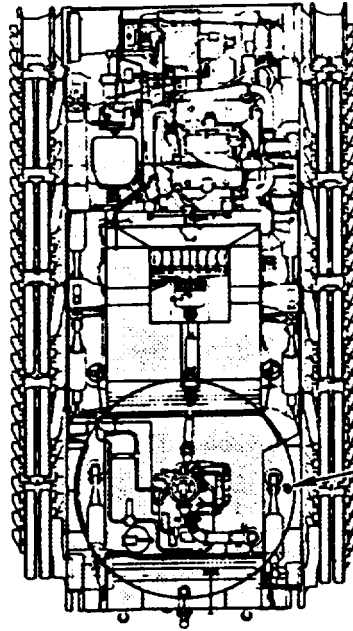

B OE/HDO Hydraulic Reservoir Drain and Fill
OEA (See Note 55) (0)

Note 55

HYDRAULIC RESERVOIR DRAIN AND FILL

Drain hydraulic reservoir.

Note

Drain only after operation.

- A Attach a drain hose to quick-disconnect fitting (1) under reservoir.
- B Open hull cleanout cover in turret well and place drain hose in opening.

CAUTION

Hydraulic reservoir contains 140 gal. (530 l) of oil.

- C Open drain valve (2) at top of quick-disconnect fitting and drain oil into a suitable container.
- D After draining, close drain valve (2), remove drain hose, and close hull cleanout cover.
- E Open reservoir fillcap (3) and fill reservoir with oil (OE/HDO or OEA) until it indicates halfway on level gage (4) in cab.

Note

Perform the following services at the same time the reservoir is drained:

- Change filter element (see Note 4).
- Clean hydraulic reservoir breather (see Note 40).
- Clean filter and strainer assembly (see Note 13).

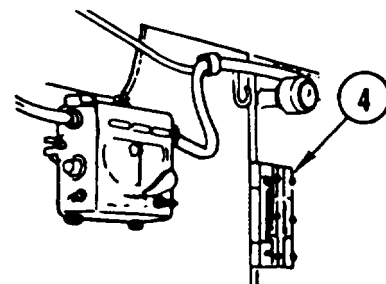
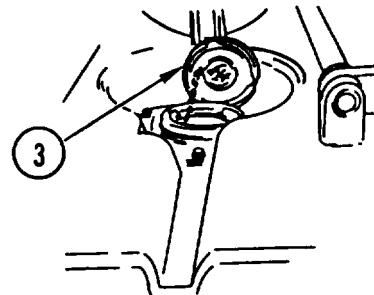
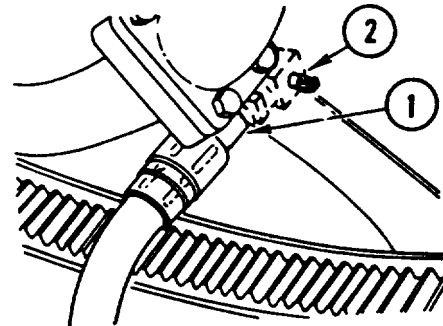

ON-CONDITION NOTES

LUBRICANT-INTERVAL

INTERVAL-LUBRICANT

Engine Crankcase
Drain
(See Note 56) (0)

OE/HDO OC
OEA

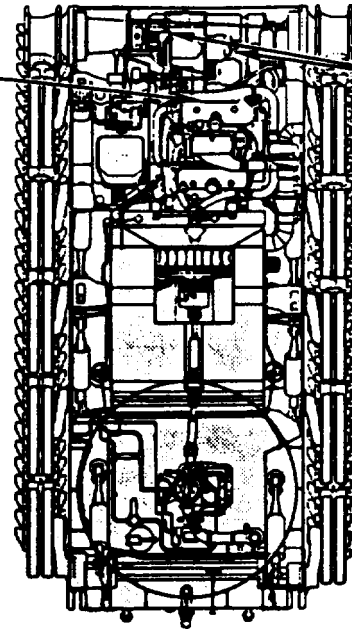

OC OEA

Transmission
Drain and Fill
(See Note 57) (0)

Note 56

ENGINE CRANKCASE DRAIN

Note

Drain only after operation.

Drain when notified by the Army Oil Analysis Program (AOAP) laboratory.

If AOAP laboratory support is not available, drain every 1500 mi (2414 km), 150 hr, or semiannually, whichever occurs first. If OEA is used, drain every 750 mi (1207 km), 75 hr, or quarterly, whichever occurs first.

A Move vehicle to level ground.

B Remove cover (1) from bottom of hull and remove drain plug (2) from engine.

C Drain oil into a suitable container.

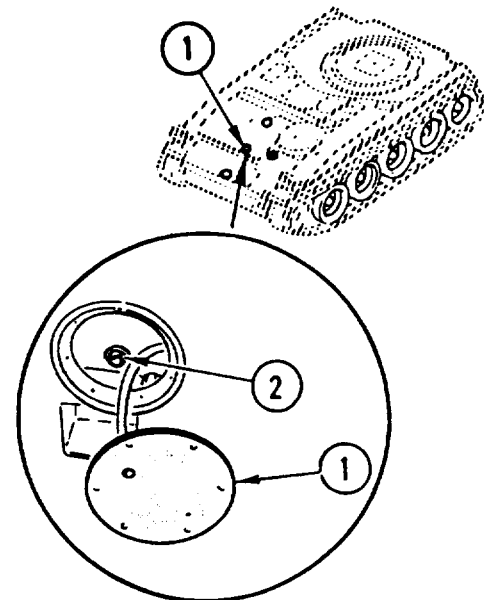

WARNING

Dry cleaning solvent (SD2) is toxic and flammable.
Wear protective goggles and gloves and use only in
well-ventilated area.

D Clean drain plug (2) and solvent SD2 and install drain plug and cover (1).

E Replace oil filter elements (see Note 28).

F Refill engine crankcase (see Note 3).

ON-CONDITION NOTS (CONTINUED)

Note 57

TRANSMISSION DRAIN AND FILL

WARNING

Oil will be hot after operation.

Drain when notified by the Army Oil Analysis Program (AOAP) laboratory.

If AOAP laboratory support is not available, drain every 1500 mi (2414 km), 150 hr, or semiannually, whichever occurs first. If OEA is used, drain every 750 mi (1207 km), 75 hr, or quarterly, whichever occurs first. Drain only after operation.

A Move vehicle to level ground.

B Remove transmission drain access cover (1) from bottom of hull, remove transmission drain plug (2) from transmission, and drain oil into a suitable container.

WARNING

Dry cleaning solvent (SD2) is toxic and flammable. Wear protective goggles and gloves and use only in well-ventilated area.

C Clean transmission drain plug (2) with solvent SD2 and install drain plug and access cover (1).

D Replace transmission oil filter (see Note 44),

CAUTION

Do NOT check oil with engine running. Do NOT overfill.

E Add oil (OEA) at transmission fill (3) until oil level is within OPERATING RANGE on gage (4).

F After filling, run engine at 1600 to 1900 rpm with brakes applied and transmission in fourth gear. Run until oil temperature gage reads 180°F (82°C).

G Run engine at 1200 to 1600 rpm for 1 to 3 min with transmission in neutral to stabilize oil temperature between 180°F (82°C) and 200°F (93°C).

H Stop engine and wait 3 to 5 minutes. Check that oil level is within OPERATING RANGE on gage (4). Do not add or drain oil if in this range, Add oil only when below ADD mark.

I Add or drain oil as required.

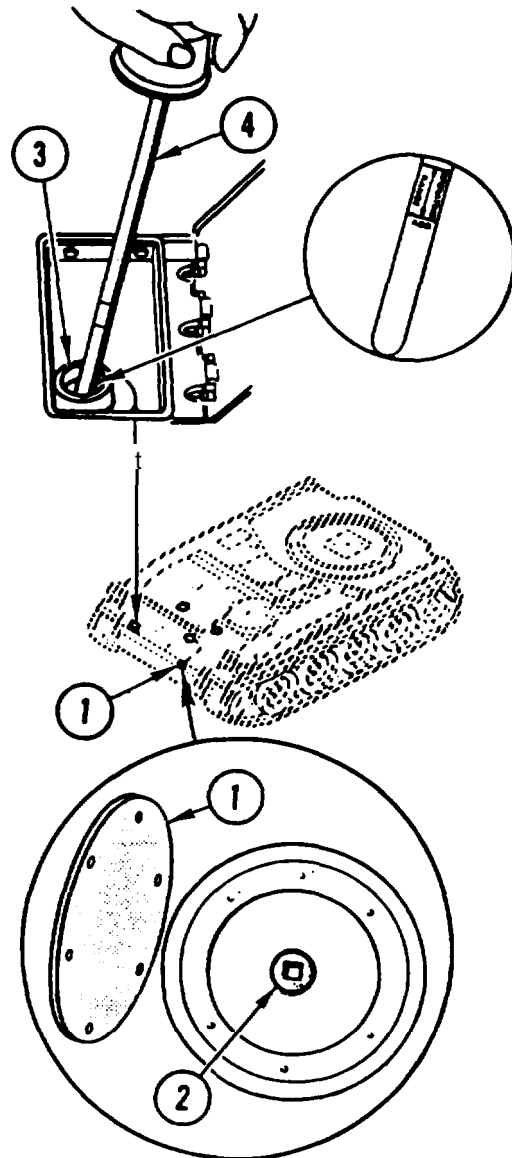

OIL CAN POINTS

Quarterly, lubricate with CLP

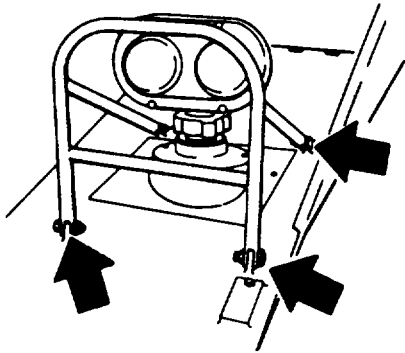

HEADLIGHT GUARD ASSEMBLY

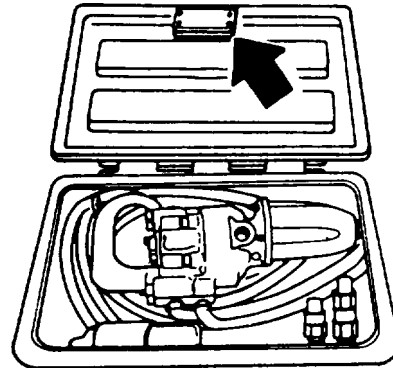

IMPACT WRENCH CONTROL ACCESS
DOOR AND LATCH HANDLE

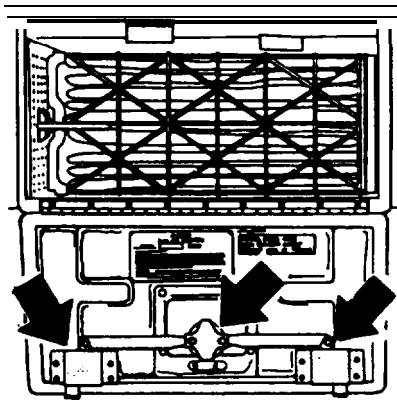

AIR CLEANER ACCESS
DOOR HINGES AND LATCH

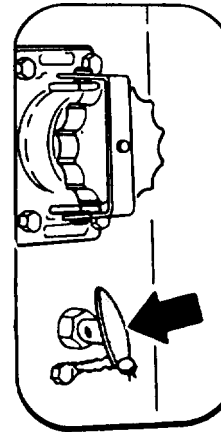

FIRE EXTINGUISHER CYLINDER
CO₂ CONTROL RELEASE (HULL
AND DRIVER'S COMPARTMENT)

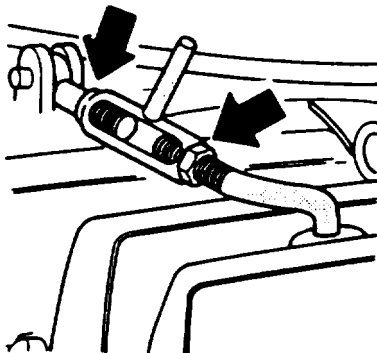

SPADE LOCK THREAD
AND HINGE

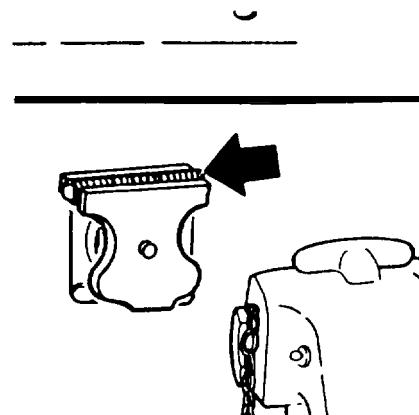

TRAILER RECEPTACLE
COVER ASSEMBLY

OIL CAN POINTS (CONTINUED)

Quarterly, lubricate with CLP

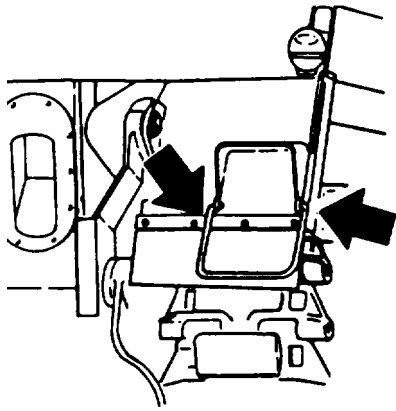

FENDER EXTENSION STEP

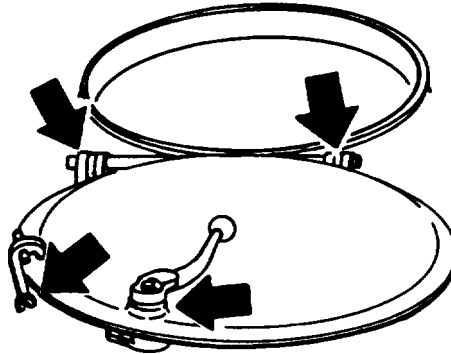

CUPOLA INNER AND OUTER HANDLES AND HINGE

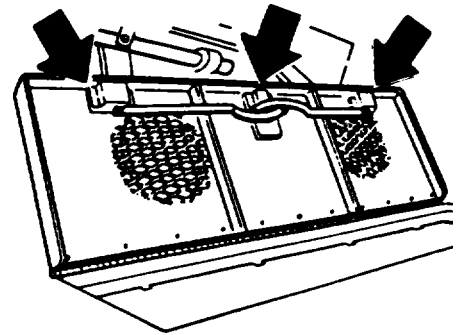

BATTERY COMPARTMENT DOOR HINGES AND LATCHES

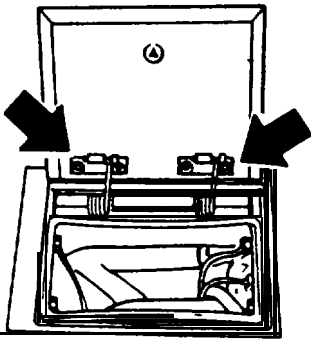

TRANSMISSION DECK DOOR HINGES

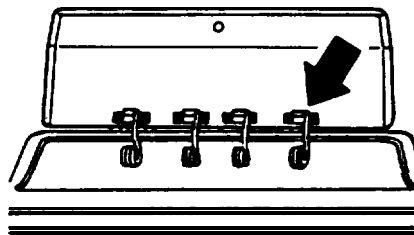

ENGINE DECK DOOR HINGES

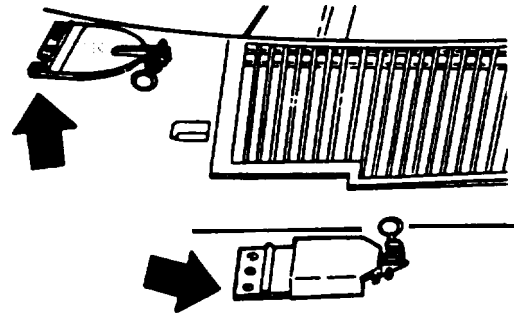

RADIATOR AND FUEL COVER HINGES

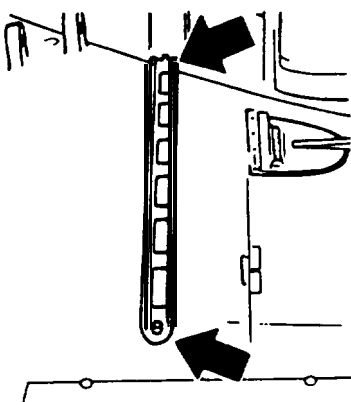

SPARE TRACK BRACKET

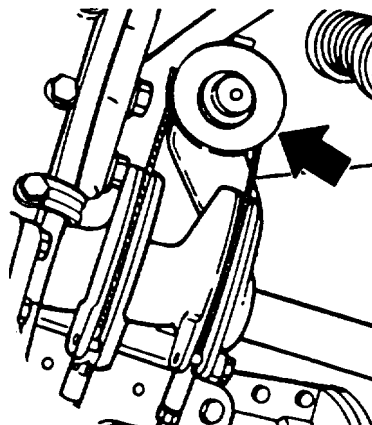

BRAKE CABLE PULLEY

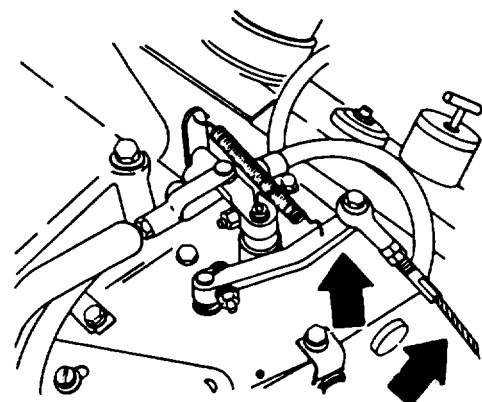

ENGINE SHUTOFF CONTROL AND CABLE

OIL CAN POINTS (CONTINUED)

Quarterly, lubricate with CLP

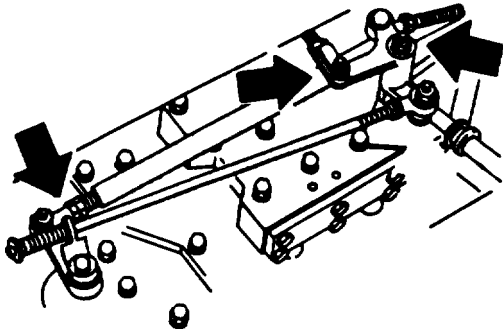

ENGINE CONTROL LINKAGE THREADED PORTION OF RODS AND YOKES

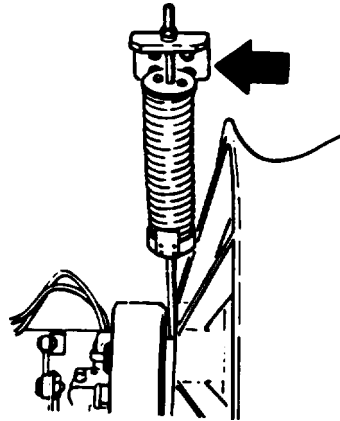

FAN BELT TENSIONER

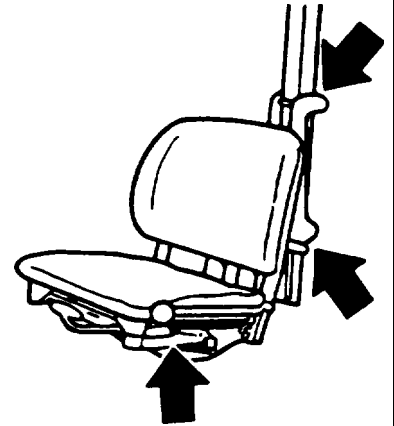

DRIVER'S SEAT MOVING PARTS

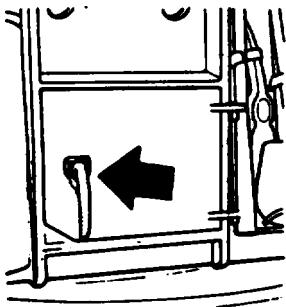

TOW CABLE ACCESS DOOR LOCK AND HINGES

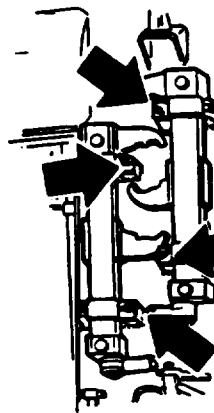

TIEDOWN BRACKETS (TYPICAL)

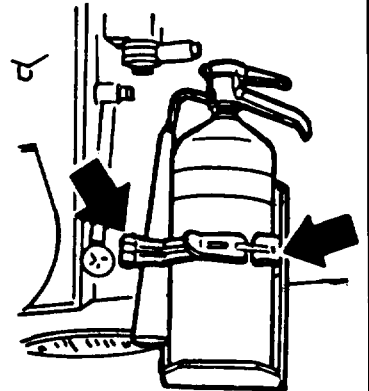

FIRE EXTINGUISHER BRACKET HINGES

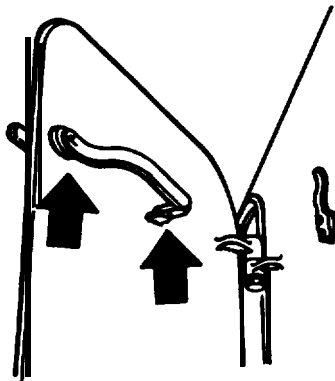

SIDE DOOR LATCHES

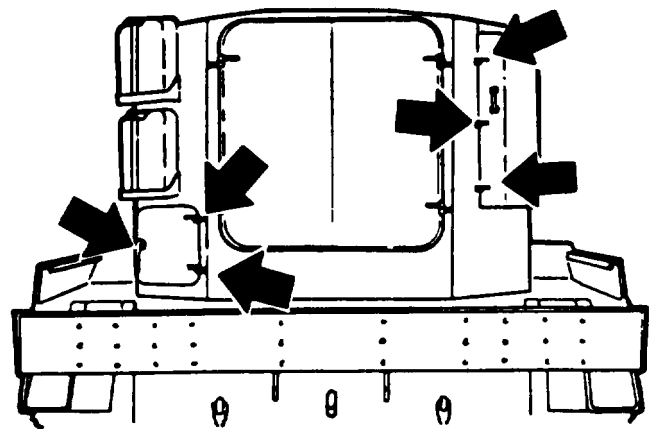

LATCH AND HINGES STORAGE BOX LATCHES

OIL CAN POINTS (CONTINUED)

Quarterly, lubricate with CLP

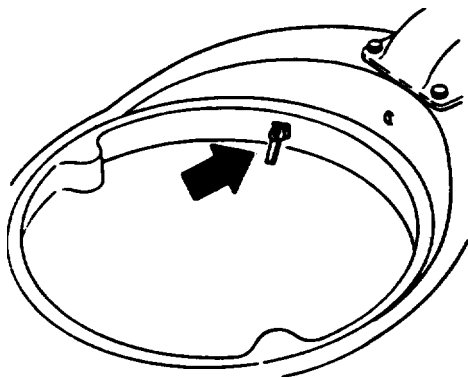

RIGGER'S CUPOLA RING LOCK

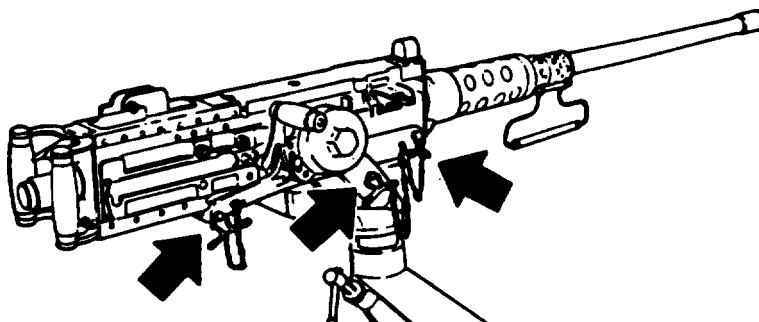

MACHINE GUN MOUNT LOCKING PINS

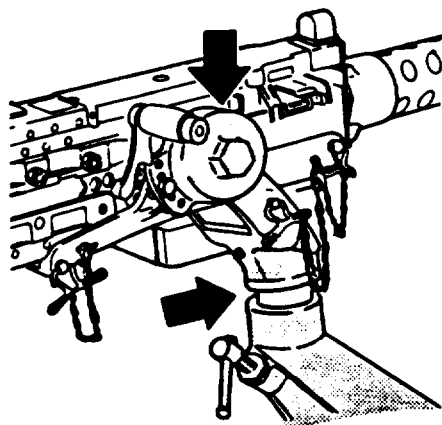

MACHINE GUN MOUNT POST, HINGE, AND PINS

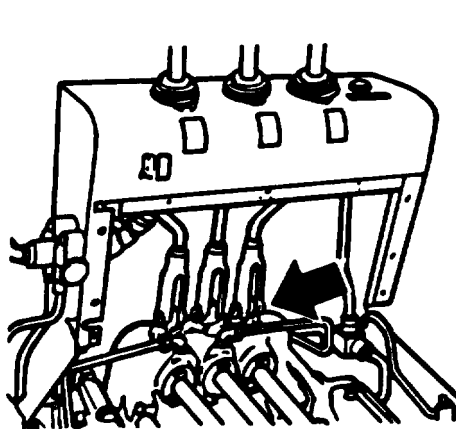

ALL CRANE OPERATING CONTROLS (TYPICAL)

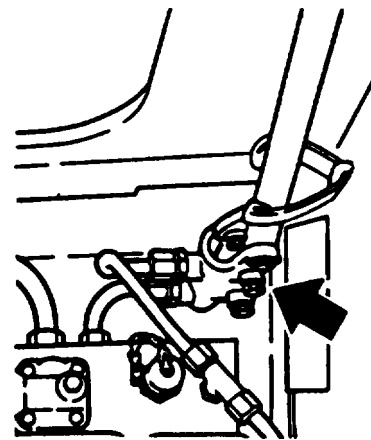

HAND OPERATED HYDRAULIC RAM PUMP

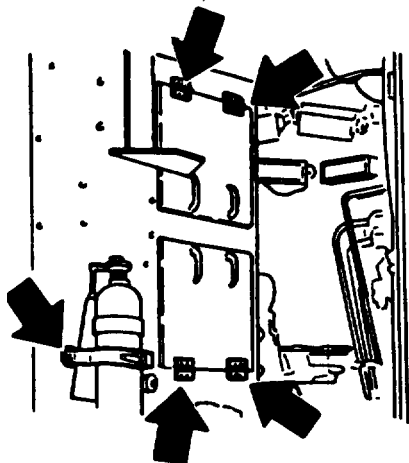

STORAGE BOX HINGES AND LOCKS AND FIRE EXTINGUISHER BRACKET HINGES

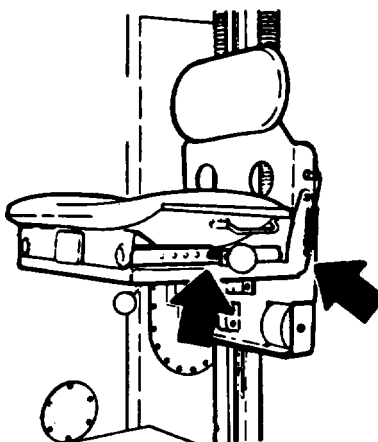

BOOM OPERATOR'S AND RIGGER'S SEATS MOVING PARTS

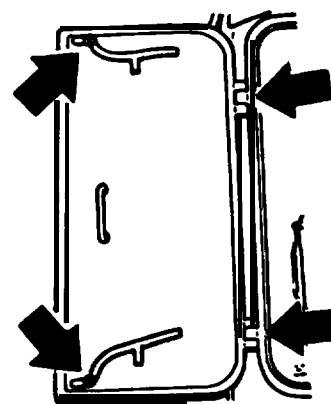

REAR DOOR LOCKS AND HINGES

OIL CAN POINTS (CONTINUED)

Quarterly, lubricate with CLP

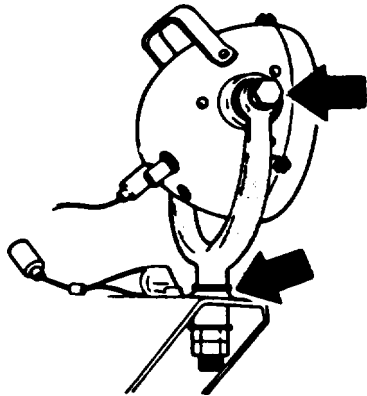

FLOODLAMP HINGE AND SWIVEL

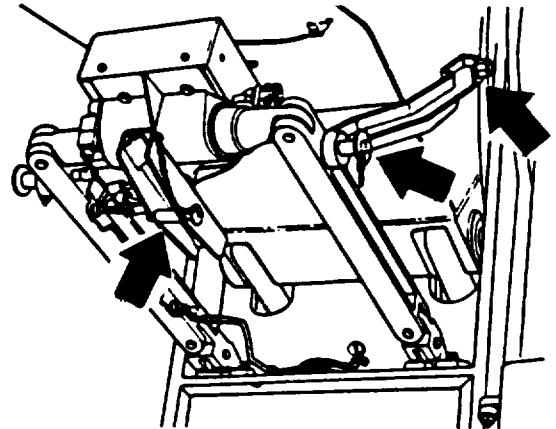

LEVEL WIND SIDE BAR CLEVIS PINS AND ARTICULATING POINTS

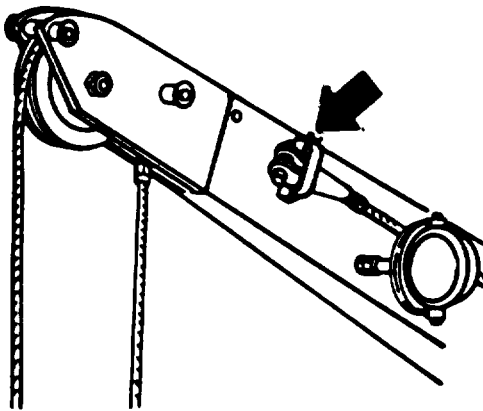

TOW CABLE STOWAGE BRACKET

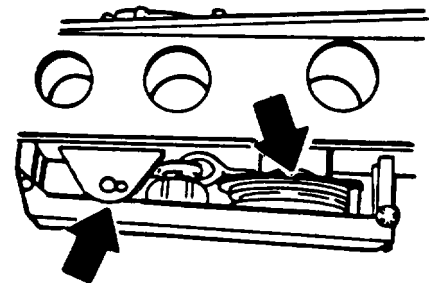

TOW CABLE SHEAVE AND HINGES

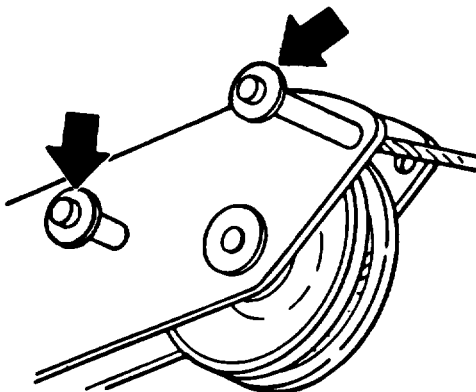

QUICK-RELEASE PINS (TYPICAL)

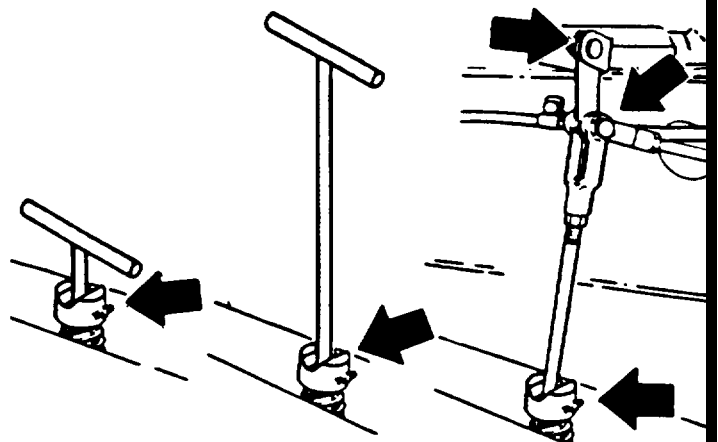

FRONT

MIDDLE

REAR

HULL DRAIN VALVES

LUBRICATED AT TIME OF ASSEMBLY BY SUPPORT MAINTENANCE

The following parts are lubricated at time of assembly:

- Starter
- Generator
- Slip ring
- Traversing drive assembly
- Magnetic clutch output shaft bearings
- Auxiliary clutch drive shaft splines
- Accelerator pedal bushings
- Vehicle control pivot points
- Towing hook pin
- Fixed fire extinguisher release mechanism
- Cupola and driver's hatch cover torsion bar splines
- Brake pedal mechanism
- Fan assembly

DO NOT LUBRICATE

Do not lubricate the following parts:

- Generator fan
- Air cleaner blower motor
- Personnel heater motor
- Driver's heater motor
- Winterization kit heater electric fuel pump and coolant pump

NOTES

- 1 New engines are delivered with preservative oil MIL-L-21260 (see DD Form 1397). Unless an oil change is necessary to meet ambient temperature requirements or until first scheduled oil change, maintain proper oil level by adding OE/HDO or OEA as required for expected temperatures.

At time of powerplant removal, clean and coat threads on engine bolt with GAA. Do not lubricate bracket mounting screws.
- 2 New transmissions are delivered with preservative oil MIL-L-21 260 (see DD Form 1397). Unless an oil change is necessary to meet ambient temperature requirements or until first scheduled oil change, maintain proper oil level by adding OE/HDO or OEA as required for expected temperatures.
- 3 Perform a quarterly lubrication after any fording operation.
- 4 Perform complete servicing of all lubrication points when a vehicle which has been in storage for an extended period of time is put into service.
- 5 Before initial start of new or overhauled engine, or one removed from storage, remove both rocker assembly covers and pour one quart of oil (OE/HDO or OEA) over rocker arms and push rods. Use oil required for expected temperature.

By Order of the Secretary of the Army:

CARL E. VUONO
General, United States Army
Chief of Staff

Official:

WILLIAM J. MEEHAN II
Brigadier General, United States Army
The Adjutant General

DISTRIBUTION:

To be distributed in accordance with DA Form 12-37, (Blocks 928, 929),
Operator and Unit Maintenance Requirements for Vehicle, Recovery, Light,
Full Tracked, M578.

RECOMMENDED CHANGES TO EQUIPMENT TECHNICAL PUBLICATIONS



THEN...JOT DOWN THE
DOPE ABOUT IT ON THIS FORM.
CAREFULLY TEAR IT OUT, FOLD IT
AND DROP IT IN THE MAIL.

SOMETHING WRONG WITH PUBLICATION

FROM: (PRINT YOUR UNIT'S COMPLETE ADDRESS)

DATE SENT

PUBLICATION NUMBER

PUBLICATION DATE

PUBLICATION TITLE

BE EXACT PIN-POINT WHERE IT IS

PAGE
NO.

PARA-
GRAPH

FIGURE
NO.

TABLE
NO.

IN THIS SPACE, TELL WHAT IS WRONG
AND WHAT SHOULD BE DONE ABOUT IT.

TEAR ALONG PERFORATED LINE

PRINTED NAME, GRADE OR TITLE AND TELEPHONE NUMBER

SIGN HERE

